

HERD Cab Guard Installation Procedure

- This document shows how to install your new Cab Guard onto your truck.
- Ensure that you have completely read and understand document **S017 - Safety** before beginning this installation procedure.

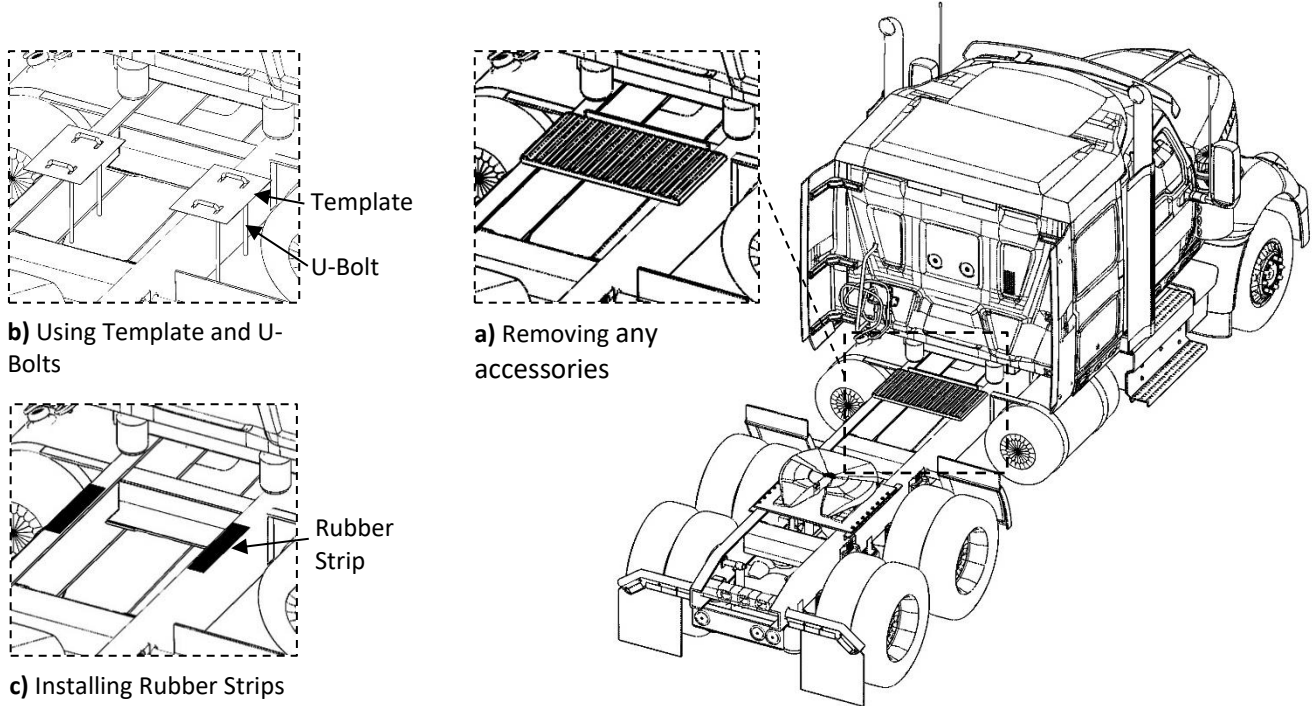

1. Preparation:

- Remove any accessories from the frame rails as shown in Figure 1a. This would include deck plates, steps, toolboxes, etc.
- Use the provided Template to locate a suitable location for installing your cab guard. The Template should be laid on your frame to help determine a mounting location with no interference as shown in Figures 1b.

Note: Additional instructions are printed on the Template itself.

- Remove the template and replace it with two rubber strips onto top of the frame rails as shown in Figures 1c.
- If you are using CG-DECKPAN, it should be placed on the frame.

2. Installing Cab Guard:

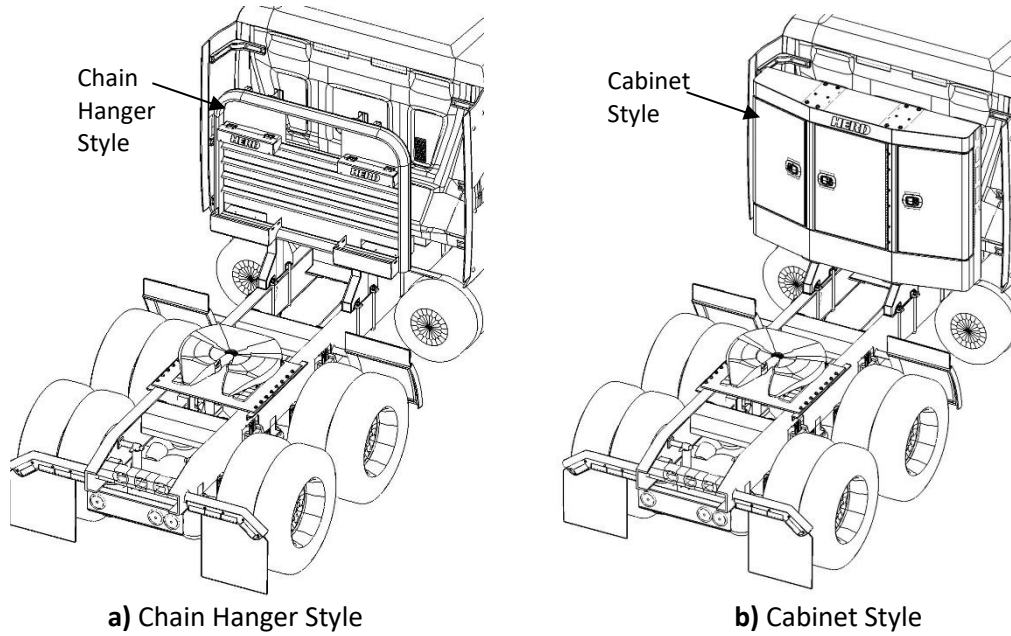

Figure 2: Cab Guard Style (Your Cab Guard may not be exactly as shown)

- Identify the type of cab guard you have based on Figures 2a and 2b.

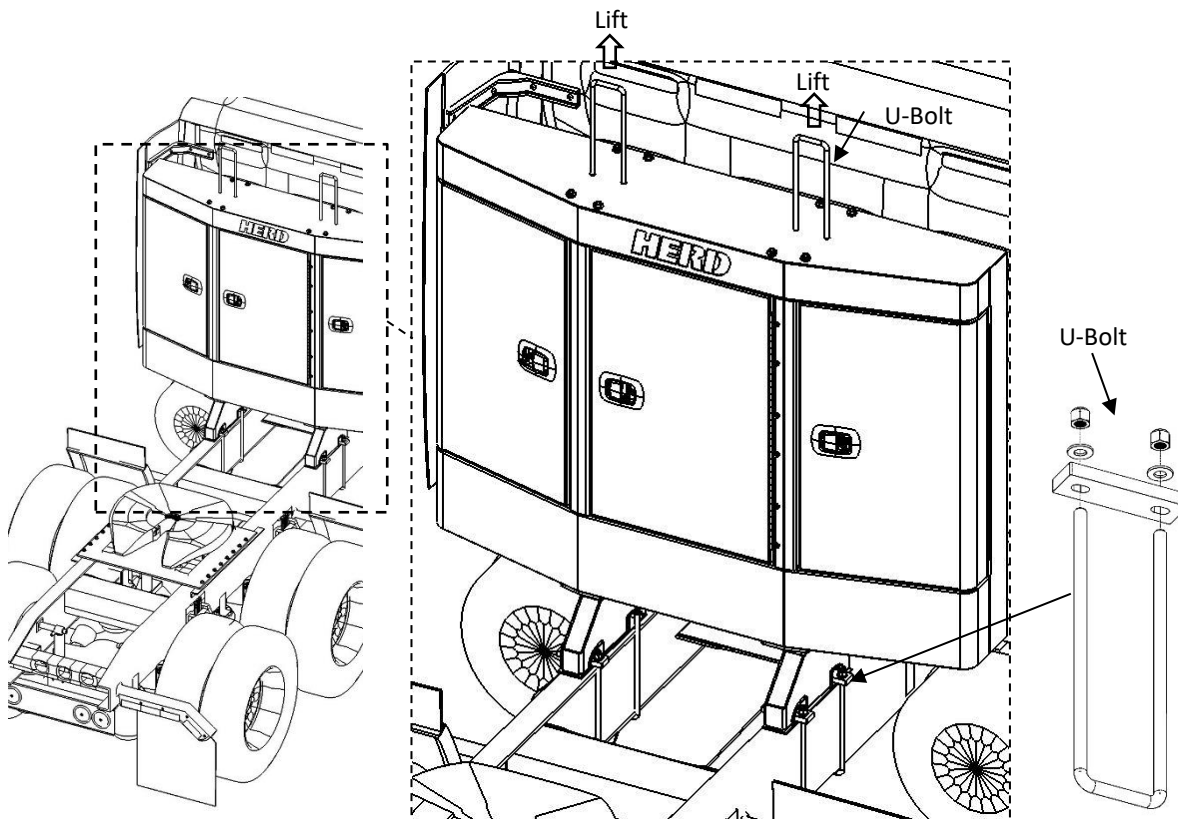

Figure 3: Cab Guard installation (Your Cab Guard may not be exactly as shown)

- b) Set the cab guard on top of the rubber strips.
 - HERD recommends using a crane to lift the cab guard onto the frame.
 - To lift cabinet style cab guards onto a truck, the U-bolts can be installed through the top of the cabinet as a lifting point as shown in Figure 3.
- c) Install U-bolts from the bottom of the frame upward, through the mounting plates as shown in Figure 3.
- d) Torque U-bolts to 180ft-lbs.

Note: U-bolts should not be reused.

Important: Check mounting point's hardware after the first 5000 km and every 3-6 months. Re-torque if necessary.

Follow the next steps if you have cabinet style cab guards

3. Installing Shelves and Hangers:

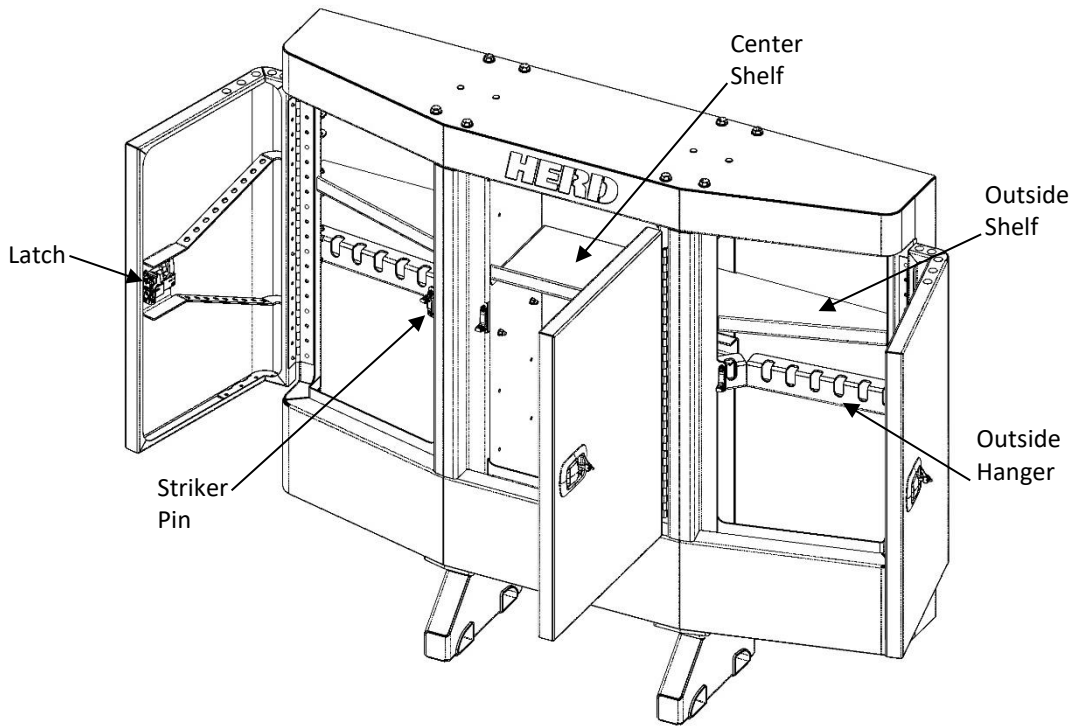

Figure 4: Cabinet style Cab Guard components (Your Cab Guard may not be exactly as shown)

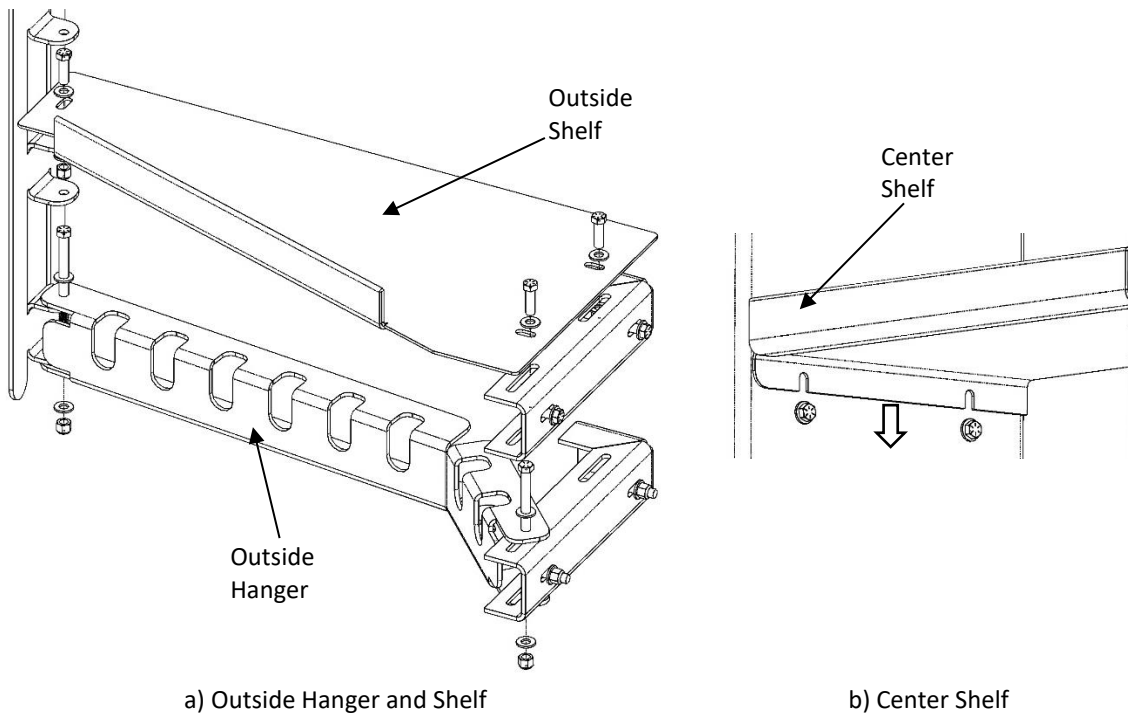

Figure 5: Hanger and Shelves installation (Your Cab Guard may not be exactly as shown)

4. Adjusting Latch:

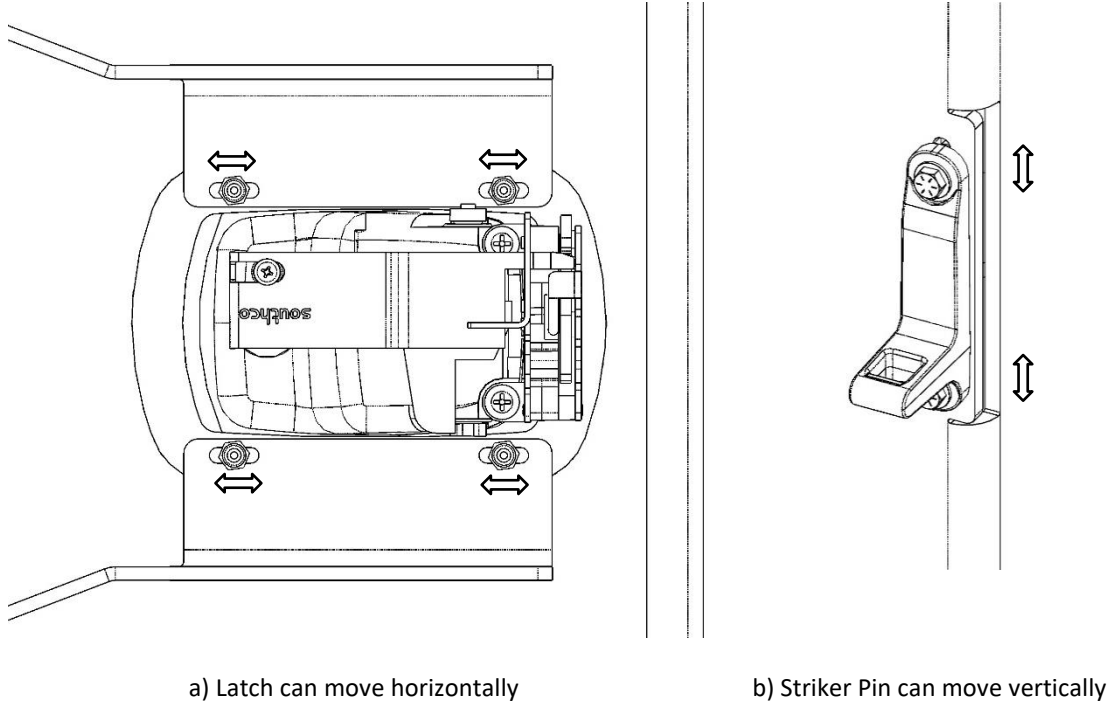

Figure 6: Latch and Striker Pin adjustment (Your Cab Guard may not be exactly as shown)

- a) Door Latch can be adjusted horizontally to correct latch missalignment.
- b) Striker Pin can be adjusted vertically to correct latch missalignment