

- This document shows how to install your new Truck Guard onto your truck.
- Ensure that you have completely read and understand document **S017 - Safety** before beginning this installation procedure.

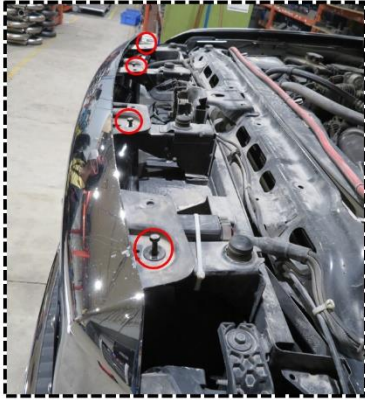

Figure 1b: Remove front grille



Figure 1a: Remove engine cover



Figure 1c: Remove bottom mounting bar (passenger side shown)



Figure 1e: Remove OEM tow loop



Figure 1d: Remove front bumper

Figure 1: Removing the OEM front bumper (Your Truck may not be exactly as shown)

I. Removing the OEM front bumper

1. Unplug the wiring harness and detach the block heater cord (if applicable) from the OEM front bumper before removing it.
2. Open the hood and remove the engine cover, see Figure 1a.
3. Remove the front grille by first removing top 4 screws as shown in Figure 1b. Next, pull the front grille away from truck to release clips.
4. Remove the bottom mounting bars (1 per side). The bars can be accessed from under the truck, see Figure 1c.
5. Remove the top 4 fasteners as shown in Figure 1d (2 fasteners are hidden inside the bumper, follow red arrows).
6. Remove the OEM front bumper then remove the 2 truck bumper mounts (4 front fasteners per side), see Figure 1e. Remove and keep the OEM tow loops together with their fasteners to be reused with HERD Truck Guard.
7. Re-attach the front grille and engine cover after removing OEM front bumper.

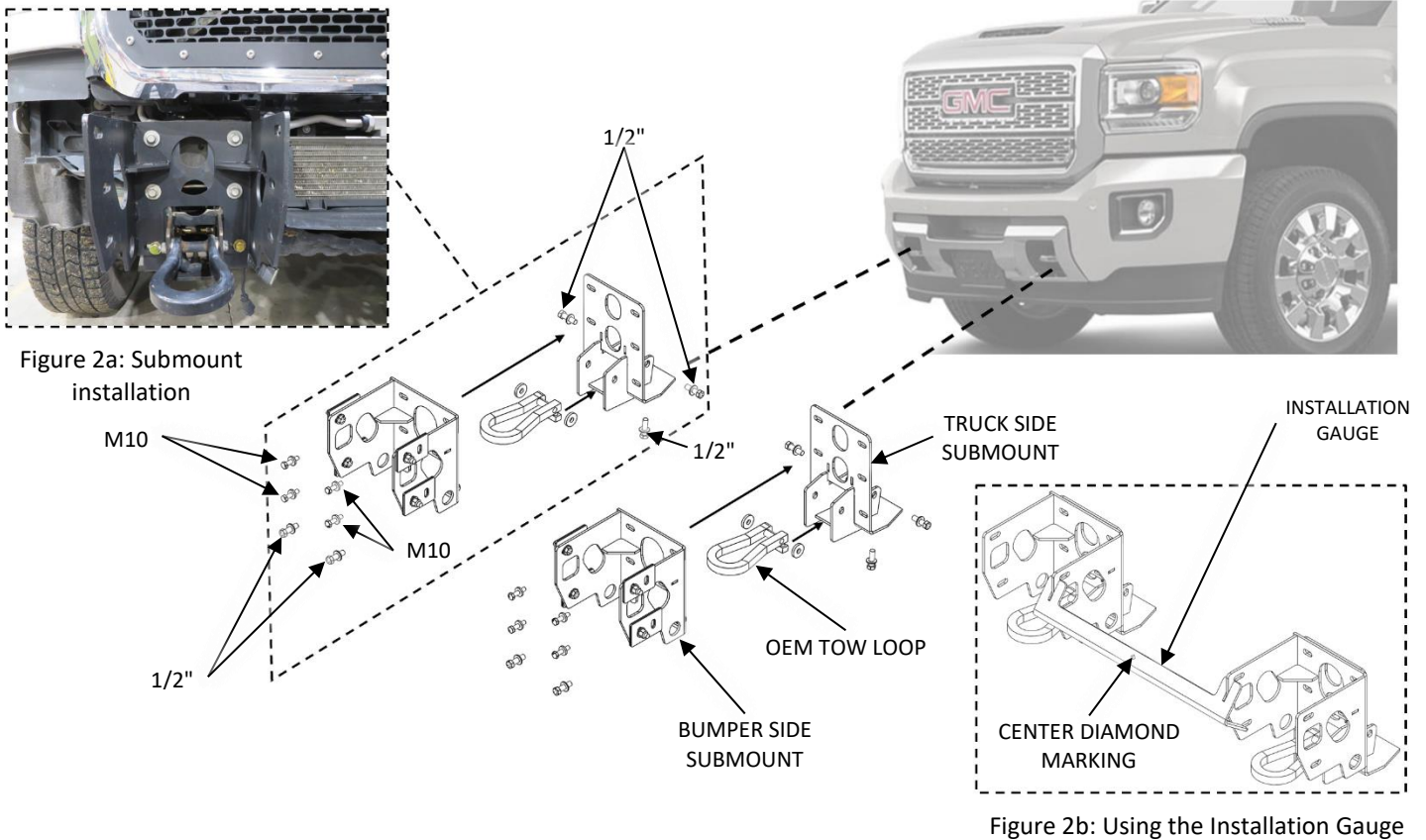

Figure 2: Installing the submounts

II. Installing the submounts

1. Install the Truck Side Submounts, shown in Figure 2, using the provided fasteners (1/2") from the side and the bottom, fasten loosely.
2. Install the OEM tow loops to the Truck Side Submounts using the OEM fasteners, see Figure 2.
3. Install the Bumper Side Submounts to the front of the Truck Side Submounts using the provided fasteners (M10 and 1/2"), fasten loosely. The Submounts set up should look like Figure 2a.
4. Use the Installation Gauge to position the Submounts; the center diamond marking should line up with the center of the truck, see Figure 2b.
5. With the Installation Gauge still in position, tighten all mounting fasteners. **Torque the M10 to 48 ft-lb; torque the 1/2" to 96 ft-lb.**
6. Remove the Installation Gauge.

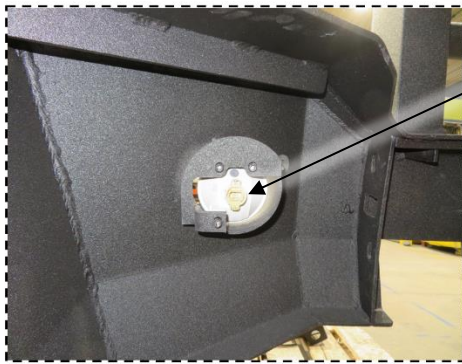
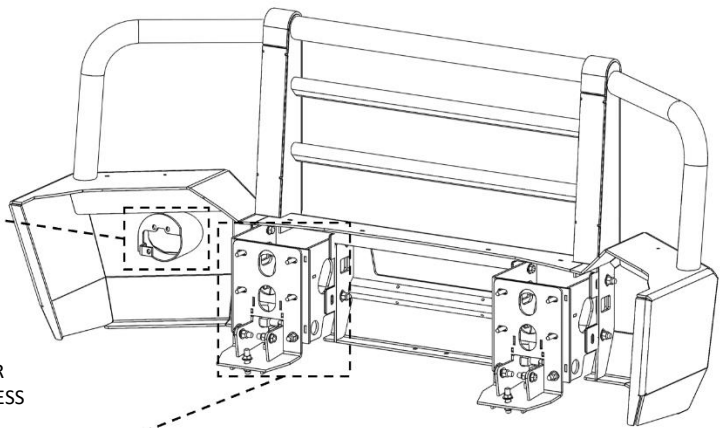

Figure 3a: OEM fog light installation (driver side shown)

OEM FOG LIGHT



CUTOUT FOR WIRING HARNESS

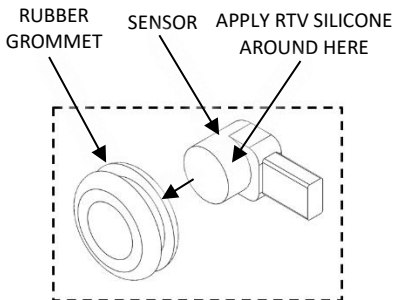

Figure 3d: Sensors installation

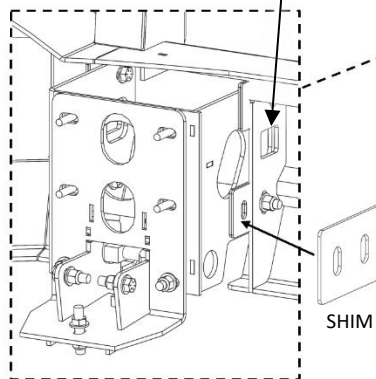

Figure 3b: Truck Guard installation (driver side shown)

SHIM

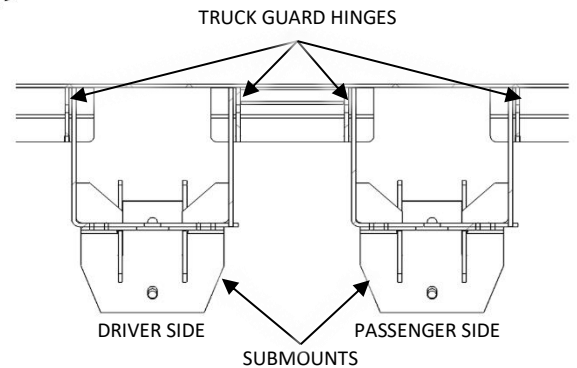

Figure 3c: Submounts position

DRIVER SIDE

PASSENGER SIDE

SUBMOUNTS

Figure 3: Installing the Truck Guard (view from behind)

III. Installing the HERD Truck Guard

1. Remove the OEM fog lights together with housing from the OEM front bumper (if applicable).
2. Install the OEM fog lights together with housing on the HERD Truck Guard using the provided OEM Light Brackets as shown in Figure 3a.
3. Attach the HERD Truck Guard to the Submounts, **follow the position shown in Figure 3b and Figure 3c**. Use the provided Shims if required. Adjust the HERD Truck Guard if necessary. Tighten all mounting fasteners (1/2") after adjustment, and **torque to 96 lb-ft**.
4. If the truck has parking sensors, remove them from the OEM front bumper (sensor's bezel is not required) together with wiring harness. Take note of the location of each sensor and harness. Apply RTV silicone all around the cylindrical section of the sensors, then insert the sensors through the rubber grommets on the HERD Truck Guard, see Figure 3d. Ensure locations of the sensors match where they were located on the OEM front bumper.
5. Plug main harness into each sensor, each fog light, and the truck's wiring harness. Wait until the adhesive cure then check if each sensor functions normally. Clean up loose wiring (harness and block heater cord) with zip ties.

Important: Check mounting point's hardware after the first 5000 km and every 3-6 months. Re-torque if necessary.