

This Guide is for all Truck Guard Models, including (where applicable):
Aero
Defender
Texas
Big Texas
Road Train
Super Road Train

Thank you for choosing HERD!

For assistance call
1-888-543-4373
www.HERD.com

Truck I.D.	Truck Models
KW01	Kenworth W900L - SFA
	

Important

- Herd Truck Guards are vehicle "Make & Model" specific. Use of a Truck Guard on a vehicle other than the model it was designed for will constitute improper use of the product and may void warranty.
- Unless otherwise specified, Grade 8 or Class 10.9 hardware is to be used. For the purposes of these instructions, OEM hardware means the truck's original factory hardware.
- For further detail of warranty coverage and warranty repair information visit www.HERD.com.

General Safety

- Take time to fully read the instructions before installing the Herd Truck Guard.
- At all times exercise safe work shop practices, wear steel toe boots and safety glasses during installation.
- Parts and components of the Herd Truck Guard can be heavy, handle with care to avoid injuries.
- Respect power tools and use them as advertised.

Reference this Parts List if your Truck Guard has a CEB (Captive Eye Bolt) Latching System

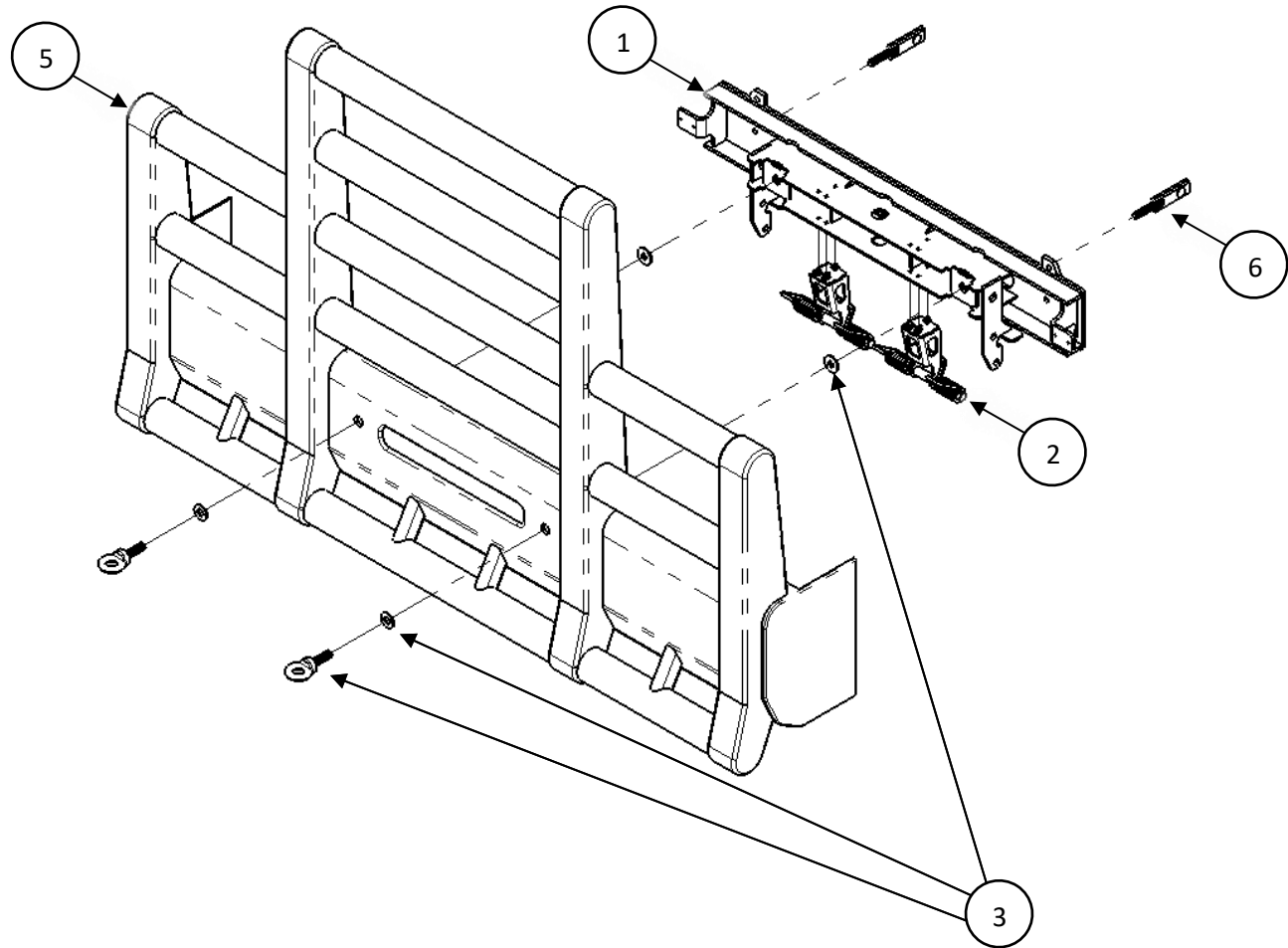

Figure 1 – Captive Eye Bolt Latching System

Table 1: Parts and Hardware Included

Item No	Part No	Description	Qty
1	BR-KW01-AT (Only with Aero, Road Train, Super Road Train, Texas, & Big Texas Versions) or BR-KW01-FLT (Only with Defender Version)	BRACKET, Kenworth W900L - SFA	1
2	1MPA027 (Only with Aero, Road Train, Super Road Train, Texas, & Big Texas Versions) or 1MPA024 (Only with Defender Version)	ASSY - LEGACY LIFT ASSIST	2
3	7-EYEBOLT KIT	CAPTIVE EYEBOLT ASSEMBLY	2
5	HERD TRUCK GUARD	TRUCK GUARD APPEARANCE MAY VARY BY SKU	1
6	1-MP-KW01.60	MOUNTING ASSEMBLY, TOW EYE, KW01	2
*7	500088	BOLT-HEX 1/2-13X2-1/2 NC GR8 YZP	6
*8	500167	NUT-NYLOCK 1/2-13 NC GR8 YZP	6
*9	500206	WASHER-FLAT 1/2 SAE GR8 YZP	12
*10	500172	NUT-NYLOCK 3/4-10 NC GR8 YZP	2
*11	500211	WASHER-FLAT 3/4 SAE GR8 YZP	2

Items marked with * are not shown in Figure 1 above

Reference this Parts List if your Truck Guard has a Slam Latch Latching System

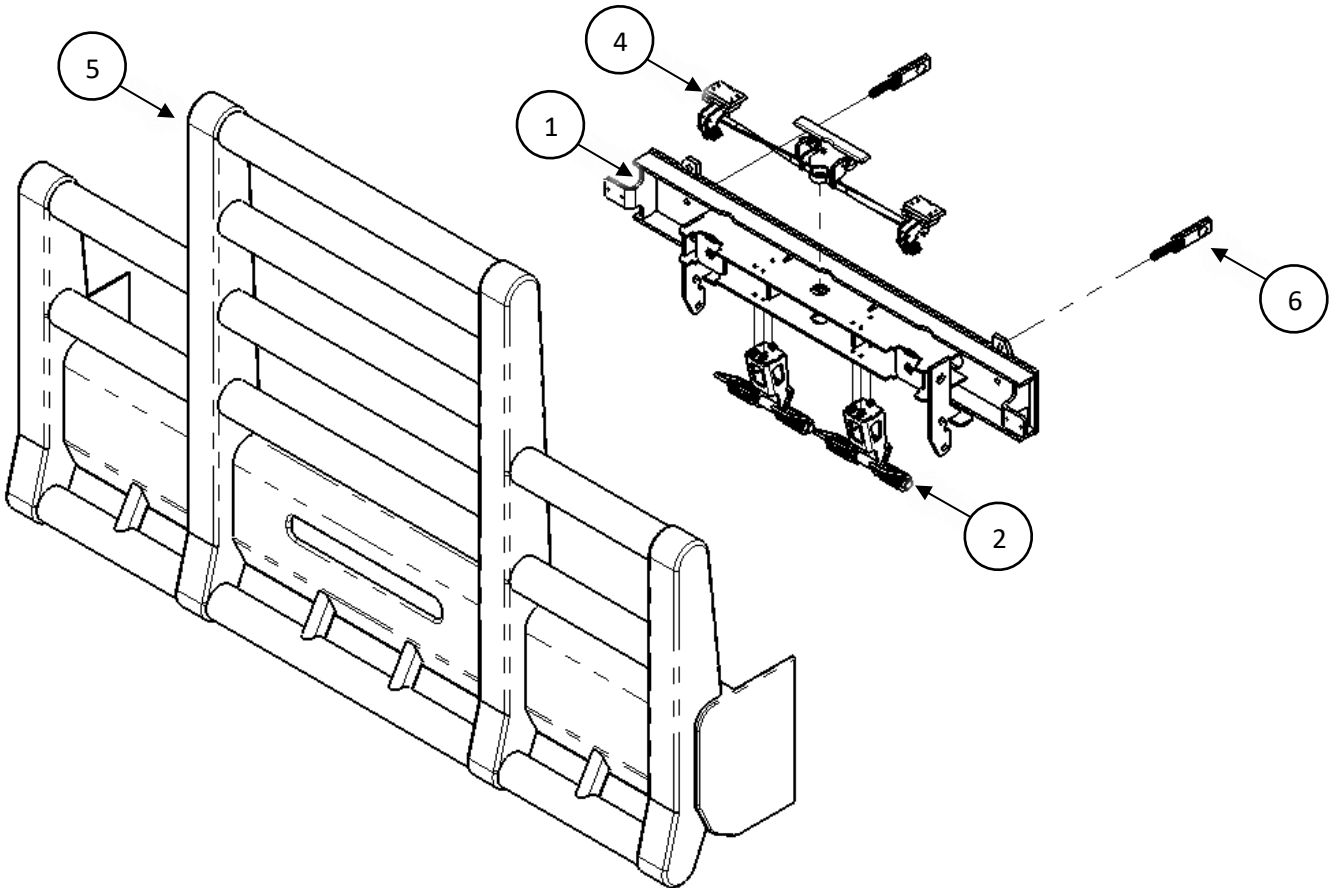

Figure 2 – Slam Latch Latching System

Table 2: Parts and Hardware Included

Item No	Part No	Description	Qty
1	BR-KW01-AT-SL (Only with Aero, Road Train, Super Road Train, Texas, & Big Texas Versions) or BR-KW01-FLT-SL (Only with Defender Version)	BRACKET, Kenworth W900L - SFA	1
2	1MPA027 (Only with Aero, Road Train, Super Road Train, Texas, & Big Texas Versions) or 1MPA024 (Only with Defender Version)	ASSY - LEGACY LIFT ASSIST	2
4	4-MC-SLA-A	ASSY- LEGACY SLAM LATCH	1
5	HERD TRUCK GUARD	TRUCK GUARD APPEARANCE MAY VARY BY SKU	1
6	1-MP-KW01.60	MOUNTING ASSEMBLY, TOW EYE, KW01	2
*7	500088	BOLT-HEX 1/2-13X2-1/2 NC GR8 YZP	6
*8	500167	NUT-NYLOCK 1/2-13 NC GR8 YZP	6
*9	500206	WASHER-FLAT 1/2 SAE GR8 YZP	12
*10	500172	NUT-NYLOCK 3/4-10 NC GR8 YZP	2
*11	500211	WASHER-FLAT 3/4 SAE GR8 YZP	2

Items marked with * are not shown in Figure 2 above

Installation Procedure

1. Remove the 6 OEM bolts on the front of the OEM bumper. Retain factory hardware. Disconnect OEM driving lights if applicable.

Remove the OEM bumper. If factory center tow pin is an option on the truck, remove it as well. If the truck has a collision mitigation radar sensor, unplug and remove it.

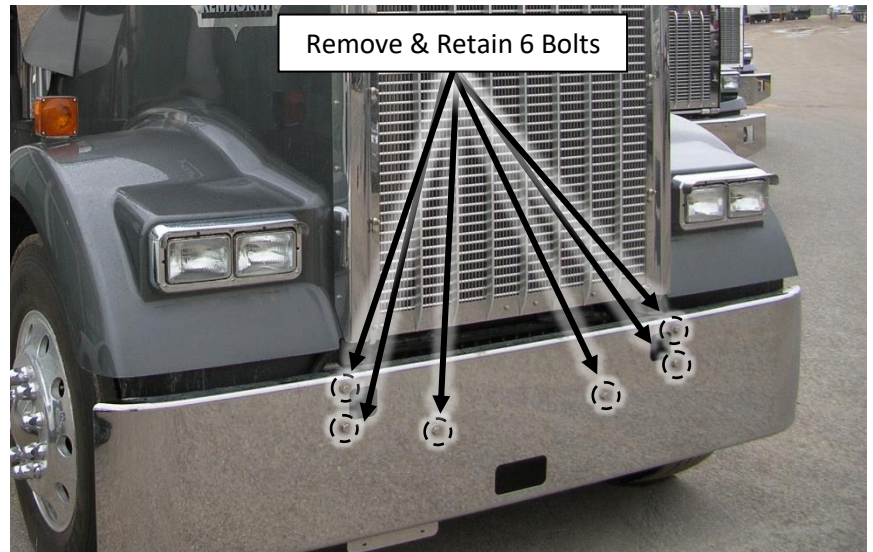

Figure 3 – OEM Bumper Removal Front View

2. Insert tow receiver inserts (Item 6) into the tow receivers on both passenger and driver sides.

Secure in place using OEM clevis pin.

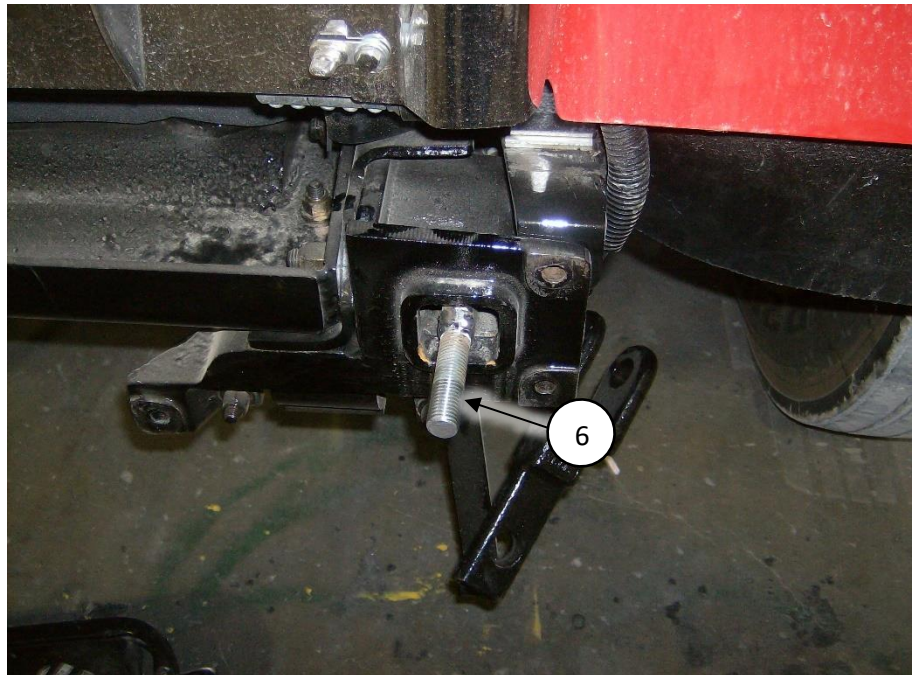

Figure 4 – Tow Receiver Insert Installation

Installation Procedure

3. Install Herd steel bracket (Item 1) to truck using supplied 1/2" hardware (Items 7, 8, 9).

Be sure all 6 mounting points are used and that the supplied packers (Part of Item 1) are used on the innermost 2 mounting points.

The 3/4" threaded rod portion of the tow receiver insert (Item 6) will pass through the backplate of the bracket and be fastened down in step 4.

Note:

If installer has a crane available, truck guard can be attached onto truck with bracket, otherwise disassemble truck guard from bracket first. Keep hardware. If bumper is equipped with lift assist, the springs must be removed. Refer to instructions S004 (Defender bumpers) or S005 (Aero/Texas bumpers) for proper lift assist disassembly procedure.

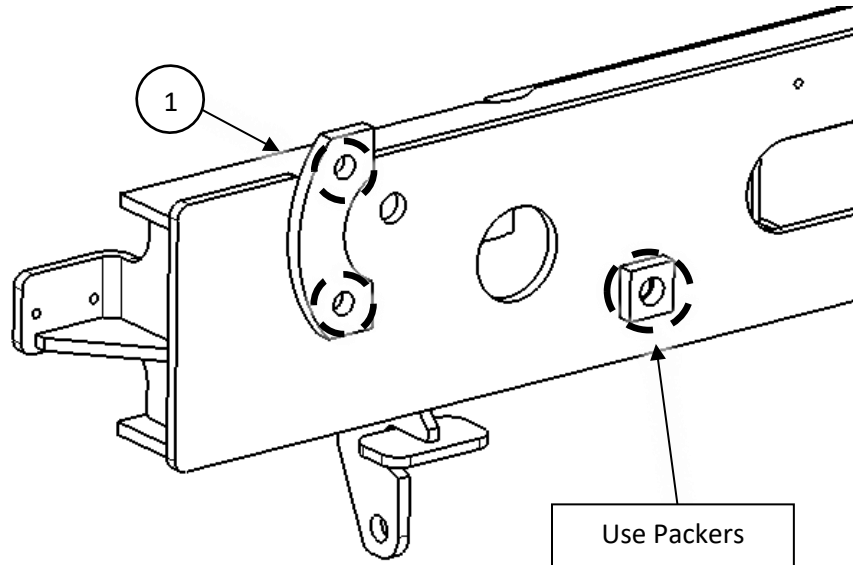

Figure 5 – HERD Bracket Installation (Driver Side Shown)

Installation Procedure

4. Tighten 3/4" nut and washer (Items 10, 11) onto threaded end of the tow receiver inserts (Item 6) to 70-80 ft-lbs. Do not overtighten.

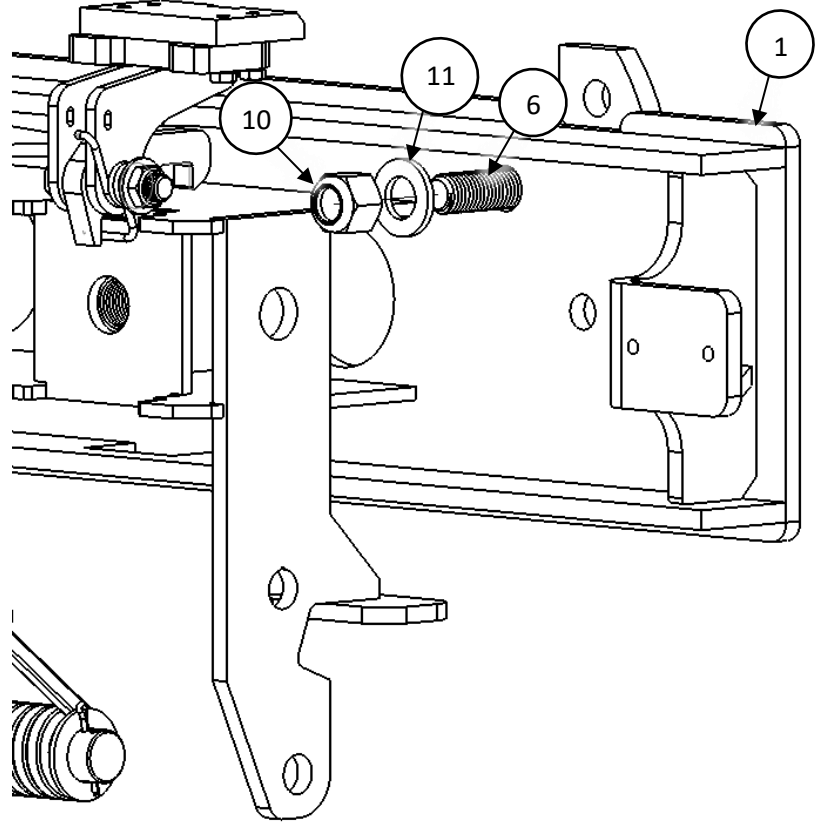

Figure 6 – HERD Bracket Installation (Driver Side Shown)

Installation Procedure

5. If the Herd Truck Guard was disassembled from bracket in step 3, reinstall Herd Truck Guard onto bracket using the hardware kept from step 3.

For DFLT & Defender models only: To install the hinge bolts, the bumper must be in the open (down) position to allow the bottom lip to go under and around the steel hinge.

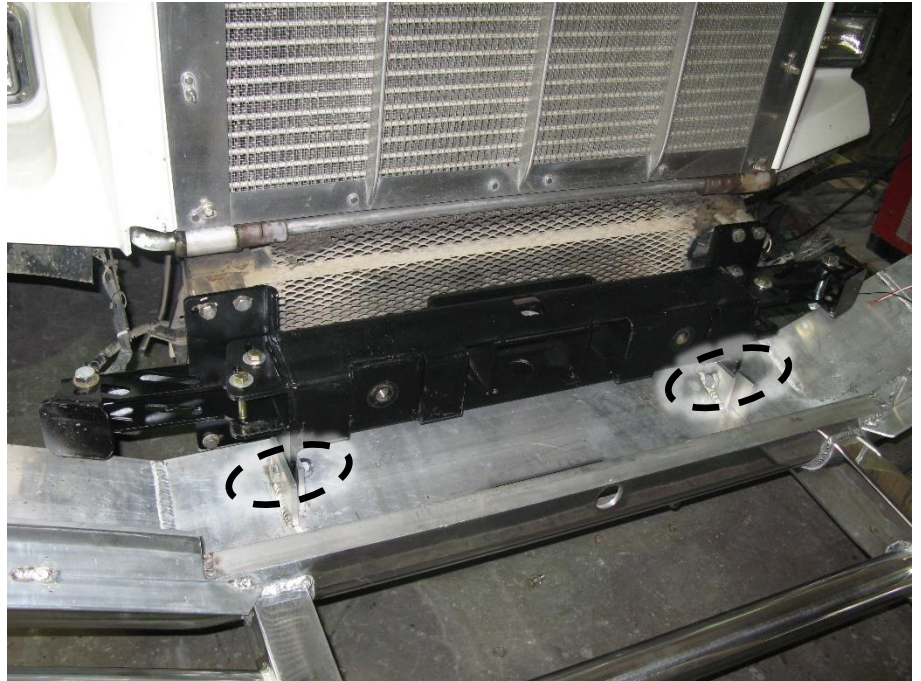

Figure 7 – View of Bracket Hinge

6. Close the truck guard and check fitment. Truck guard position can be adjusted side to side and up or down as required. Once fitment is confirmed, tighten all mounting bolts. Torque 3/4" hardware to 75lb-ft. Torque 1/2" and 5/8" hardware to 110lb-ft.



Figure 8 – Herd Truck Guard Installed

Important

- Check mounting points after the first 5000 km and every 3-6 months.
- If this truck guard is equipped with Legacy Herd Slam Latch, periodic adjustment is required. Refer to Legacy Slam Latch Installation adjustment instructions to properly adjust your Slam Latch.
- The drop-forged eyebolts are an integral part of the strength of Herd Truck Guards. When tightened firmly, they will minimize vibration and provide superior impact resistance.
- To help maintain the factory finish, avoid acid wash.

Installation Procedure

