

HERD PB10G2/G3 Installation Procedure

- This document shows how to install your new Grille Guard onto your truck.
- Ensure that you have completely read and understand document **S017 - Safety** before beginning this installation procedure.

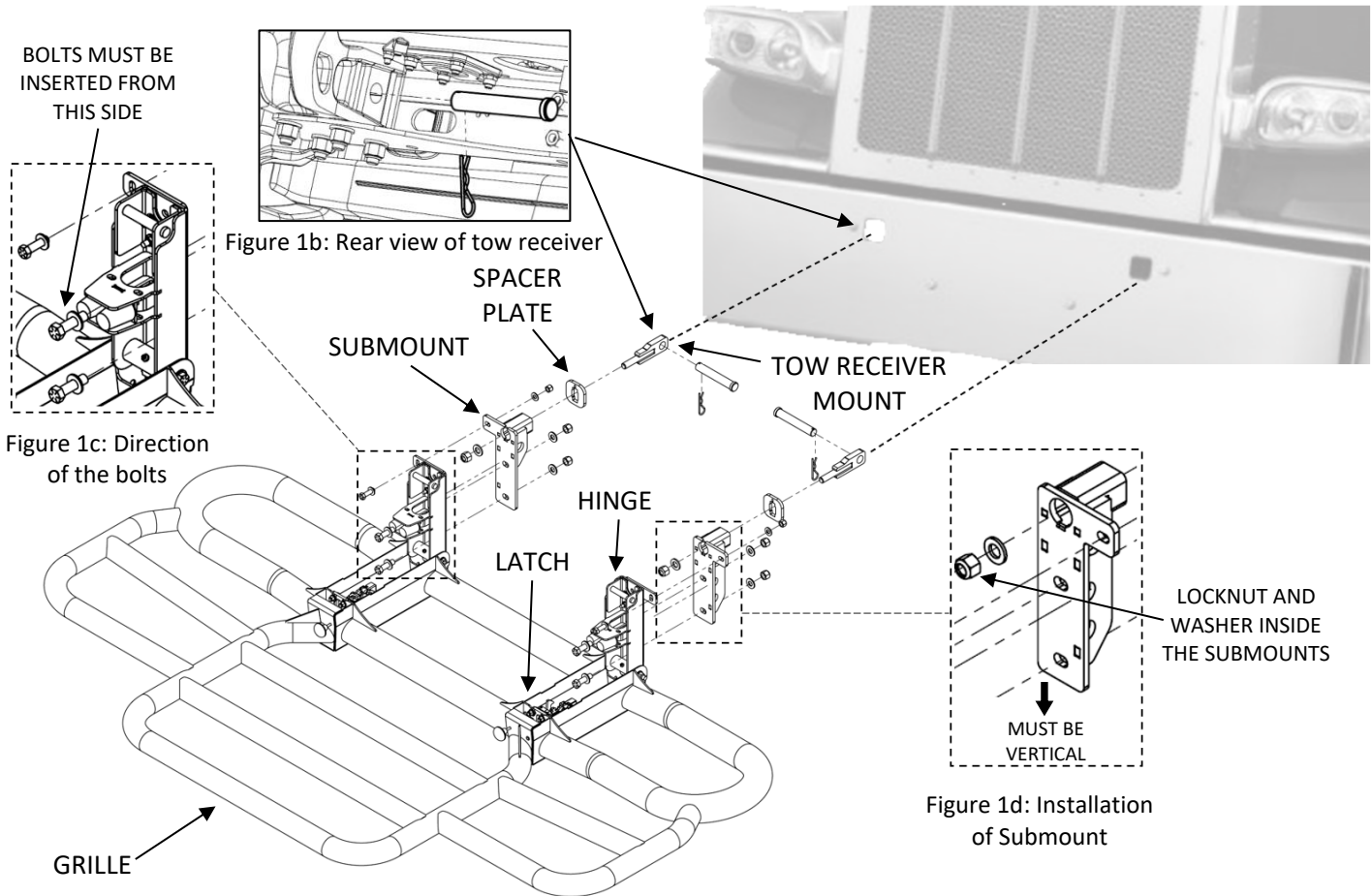

Figure 1a: Grille Guard installation (Your Grille Guard may not be exactly as shown)

1. Insert Tow Receiver Mounts into tow receivers on truck. Spacer Plate is installed directly onto front of Tow Receiver. Secure using Clevis Pins and Hairpins (Figure 1b).
2. Install Submounts over Tow Receiver Mounts (**Orientation shown in Figure 1d**). Torque lock nut into Submounts on threaded rod of Tow Receiver Mounts (Figure 1d) to 240 ft-lb.
3. Lay Grille flat on ground in front of truck on a pallet or protective sheet.
4. Open driver side Hinge and lift to driver side Submount. Hand tighten middle hardware (5/8") shown in Figure 1a (**do not fully tighten**). Repeat for passenger side. **Ensure bolts are inserted from front (Hinge side) as shown in Figure 1c.**
5. Assemble lower hardware (5/8") and upper hardware (1/2") on both sides. Hand tighten hardware (**do not fully tighten**). After all six fasteners have been assembled, **torque to 110 ft-lb (5/8") and 55 ft-lb (1/2")**, starting with middle hardware.
6. Please proceed to document **S018 – Grille Guard Latch Adjustment Procedure** for Latch adjustment.

Important: Check mounting point's hardware after the first 5000 km and every 3-6 months. Re-torque if necessary.