

HERD PK26BG/G2-02/G3-02 Installation Procedure

- This document shows how to install your new Bumper Guard/Grille Guard onto your truck.
- Ensure that you have completely read and understand document **S017 - Safety** before beginning this installation procedure.

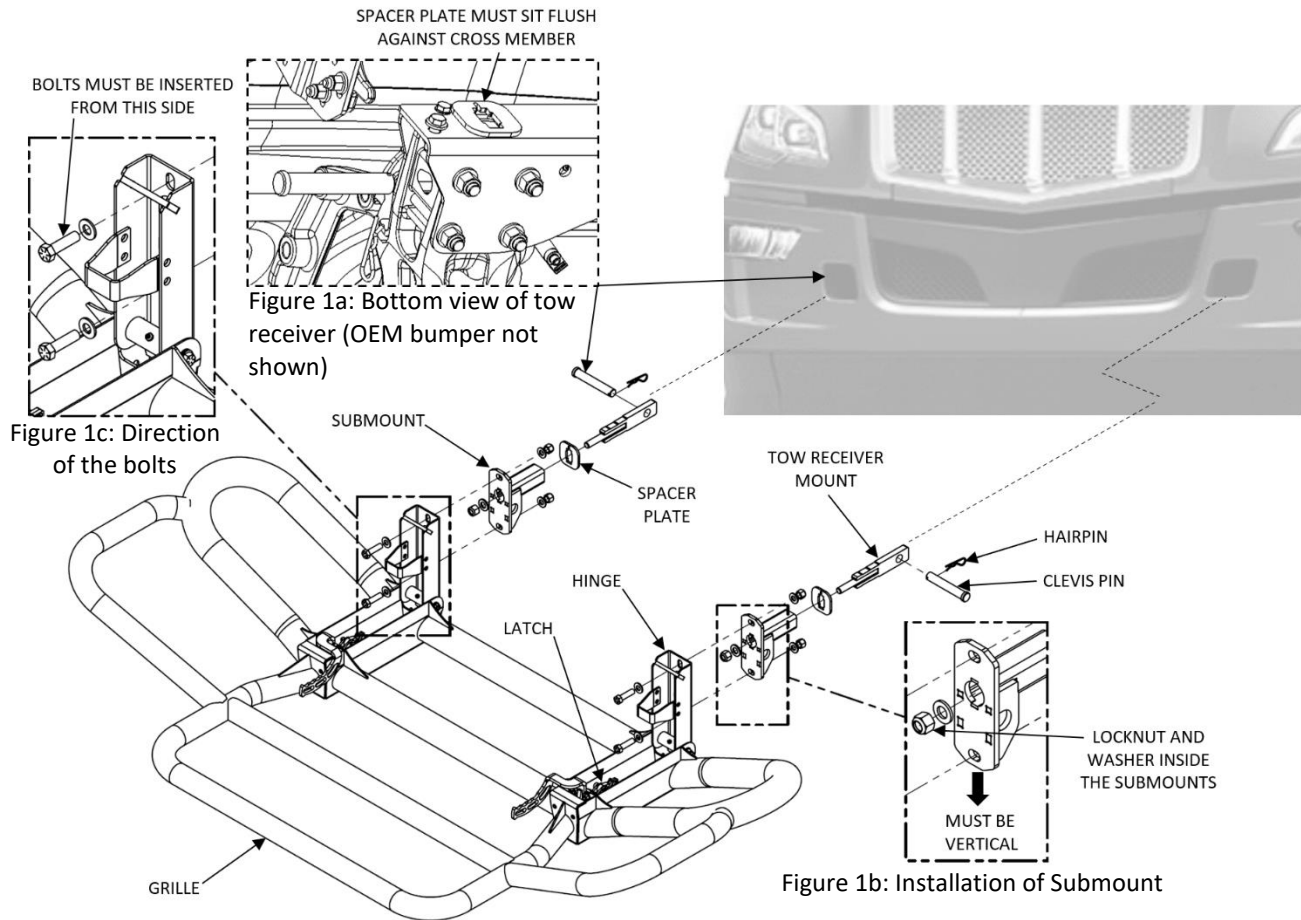

Figure 1: Guard installation (Your Guard may not be exactly as shown)

1. Install Spacer Plate and Tow Receiver Mount into truck's tow receiver as shown in Figure 1a; ensure Spacer Plate sits flush against Cross-Member. Secure using provided Clevis Pin and Hairpin. Perform this step on both driver and passenger sides.
2. Install Submounts vertically over Tow Receiver Mounts using provided hardware (3/4") (**Orientation shown in Figure 1b**). **Torque lock nut into Submounts on threaded rod of Tow Receiver Mounts (Figure 1b) to 240 ft-lb.**
3. Lay Grille flat on ground in front of truck on a pallet or protective sheet.
4. Open driver side Hinge and lift to driver side Submount. Hand tighten upper hardware shown in Figure 1 (**do not fully tighten**). Repeat for passenger side. **Ensure bolts are inserted from front (Hinge side) as shown in Figure 1c.**

NOTE: For Peterbilt New Model 579 trucks, verify that the guard is raised appropriately to ensure fog light beam is not obstructed by the guard.

5. Assemble lower hardware on both sides. Hand tighten hardware (**do not fully tighten**). After all four fasteners have been assembled, **torque to 110 ft-lb**, starting with upper hardware.
6. Please proceed to document **S018 – Bumper Guard/Grille Guard Latch Adjustment Procedure** for Latch adjustment.

Important: Check mounting points' hardware after the first 5000 km and every 3-6 months. Re-torque if necessary.