

Thank you for choosing HERD!

For assistance call
1-888-543-4373
www.HERD.com

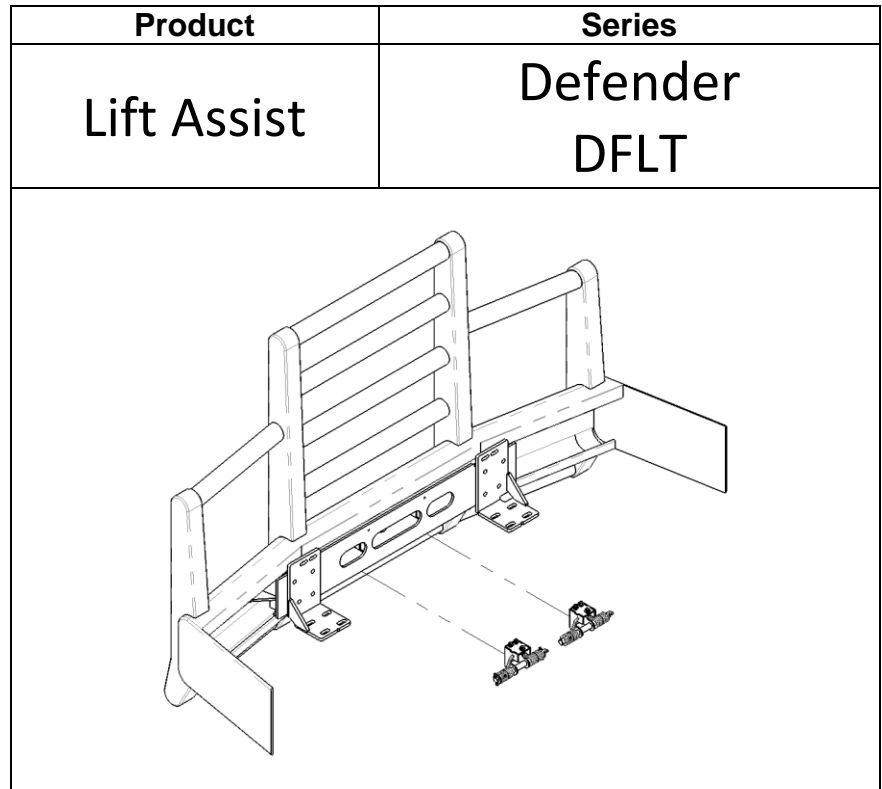

Important

- Herd Bumpers are vehicle "Make & Model" specific. Use of a bumper on a vehicle other than the model it was designed for will constitute improper use of the product and may void warranty.
- Unless otherwise specified, Grade 8 or Class 10.9 hardware is to be used. For the purposes of these instructions, OE hardware means the truck's original factory hardware.
- For further detail of warranty coverage and warranty repair information visit www.HERD.com.

General Safety

- Take time to fully read the instructions before installing the Lift Assist mechanism.
- At all times exercise safe work shop practices, wear steel toe boots and safety glasses during installation.
- Parts and components of the Herd bumper can be heavy, handle with care to avoid injuries.
- Respect power tools and use them as advertized.

HERD North America Inc.
2168 Springfield Road
Box 28, Group 525, RR5
Winnipeg, MB. Canada R2C 2Z2

Parts and tools referenced in this instruction

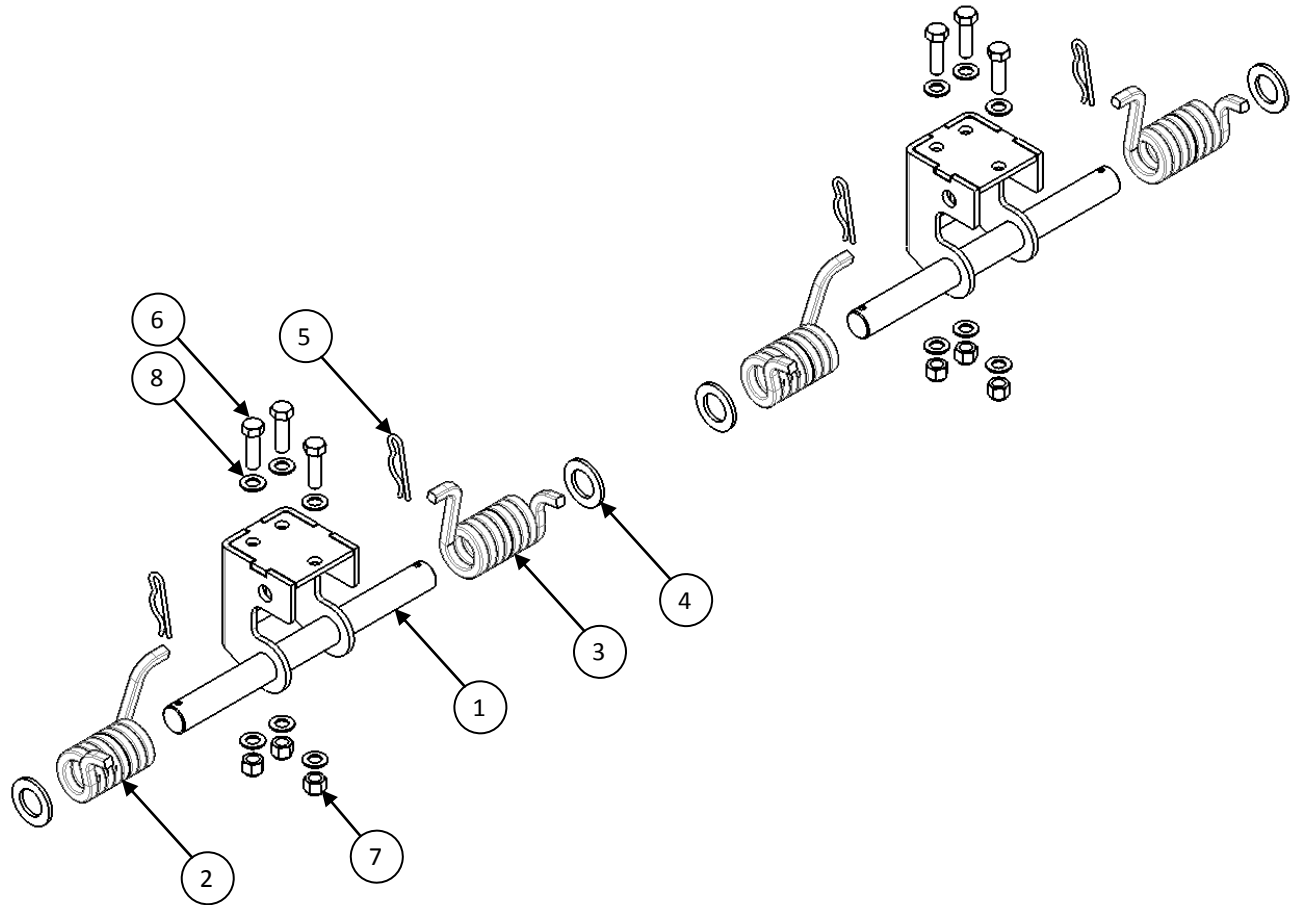

Parts and hardware included

Item No	Part No	Description	Qty
1	1MPA023	Defender spring hanger subassembly	2
2	1-MC-TS-4-RH	157.5 right handed torsion spring	2
3	1-MC-TS-4-LH	157.5 left handed torsion spring	2
4	1HN014	Washer	4
5	HP 0.125X2.5	1/8" X 2-1/2" hair pin	4
6	HB 0.375-16x1.25 FT GR8	3/8"-16 X 1-1/4" hex bolt, fully threaded, grade 8	6
7	NLN 0.375-16 GR8	3/8"-16 nylon lock nut, grade 8	6
8	FW 0.375 GR8	3/8" flat washer, grade 8	12

Tools Required

Tool	Specification
Ratchet	-
Torque wrench	-
Socket	9/16" or 14 mm
Wrench	9/16" or 14 mm

Installation Procedure

1. Open bumper and attach spring hanger subassemblies (Item 1) to mounting bracket as shown. Fully tighten bolts to 45 ft-lb.

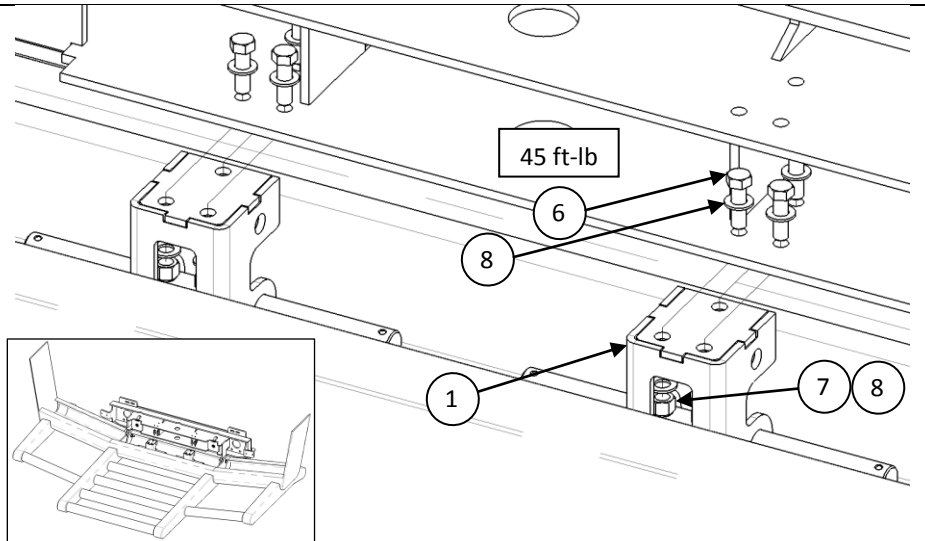

Figure 1 – Spring hanger subassembly installation.

2. Feed torsion springs (Items 2 and 3) onto spring hanger shafts as shown. Do not slide springs all the way down the shaft. Ensure there is clearance so that spring arms will not collide with spring hanger mounts when closing bumper.

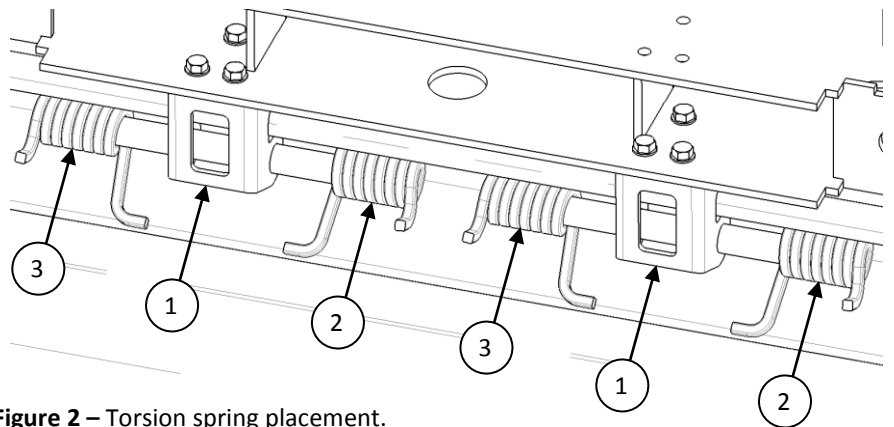

Figure 2 – Torsion spring placement.

3. Close the bumper. When viewing from the back, rotate the springs into alignment with their corresponding retaining holes and insert spring arms into holes. Completely slide spring arms into holes until they stop. Do this for all four springs.

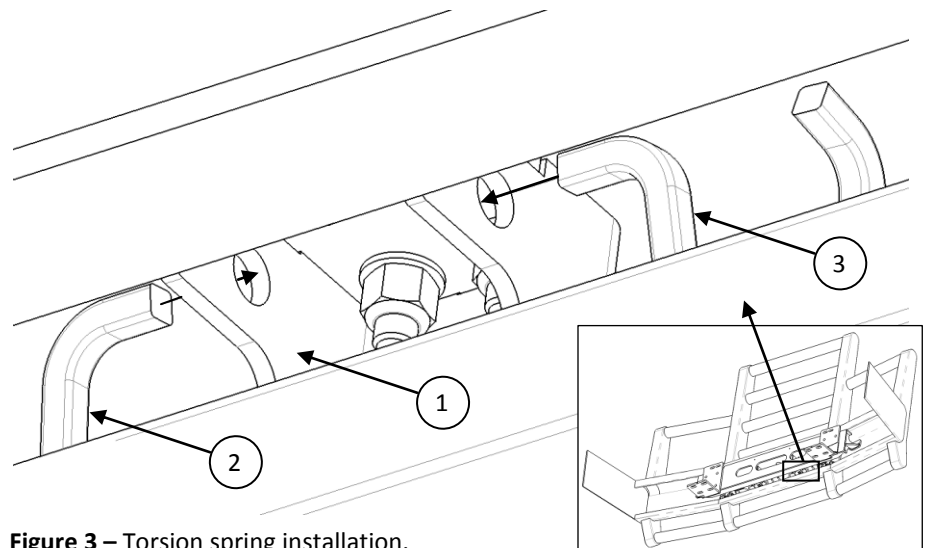

Figure 3 – Torsion spring installation.

Installation Procedure

4. Open the bumper. Install washers (Item 4) onto spring hanger shafts to retain springs in place.

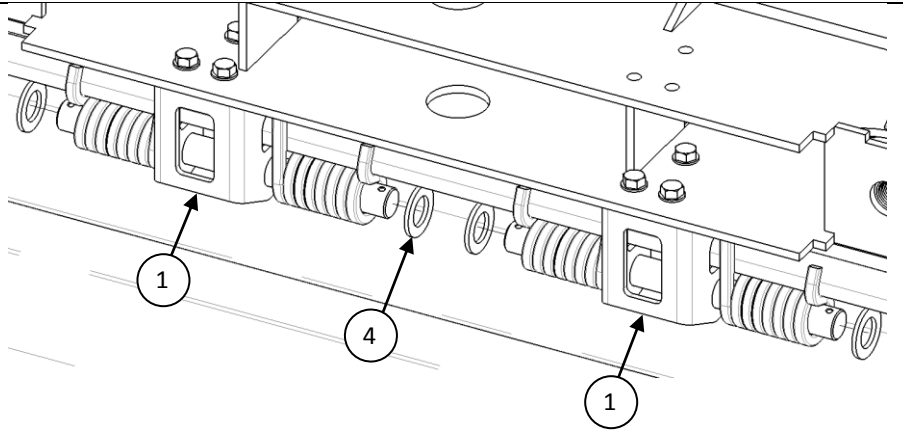

Figure 4 – Washer installation.

5. Insert hair pins (Item 5) through holes of spring hanger shafts to retain washers and springs. Close the bumper to ensure Lift Assist mechanism works as intended. Installation is complete.

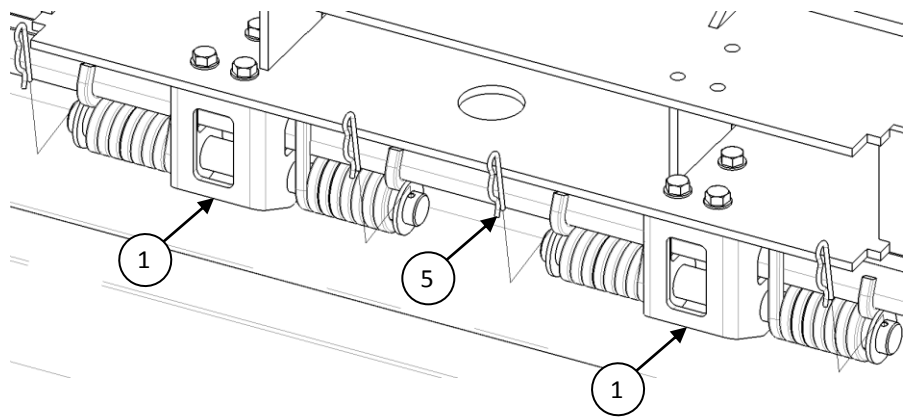

Figure 5 – Hair pin installation.