

INTERNATIONAL

Item #	Vehicle Description
IN12	International 4100, 4200, 4300, 4400 & DuraStar (without air ride cab)

IMPORTANT

- A** Herd Bullbars are vehicle "Make & Model" specific. Use of a bullbar on a vehicle other than the model it was designed for will constitute improper use of the product and may void warranty.
- B** Unless otherwise specified, Grade 8 hardware is to be used. For the purposes of these instructions, OE hardware means the truck's original factory hardware.
- C** The drop-forged eyebolts are an integral part of the strength of Herd bullbars. When tightened firmly, they will minimize vibration and provide superior impact resistance.
- D** To help maintain the factory finish, avoid acid wash.

Step

- 1 Remove factory bumper
- 2 Remove factory tow hooks
- 3 Attach appropriate sub mounts as shown below using Herd-supplied hardware (extra submounts can be discarded)

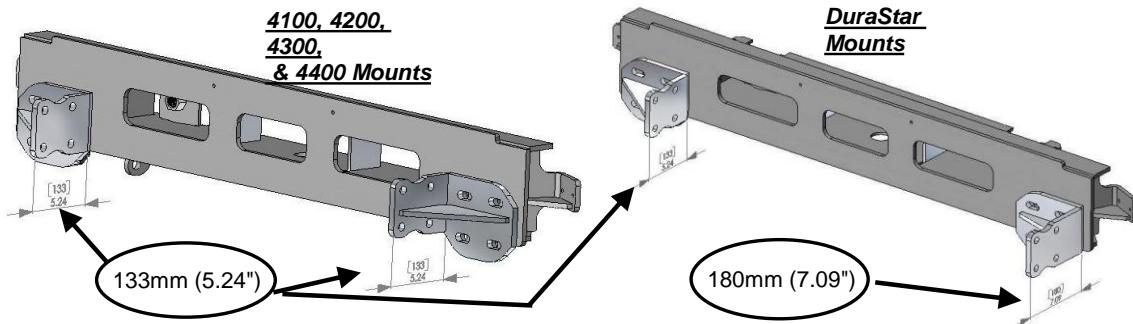

- 4 Install Herd steel bracket to truck using OE hardware (see picture)
- 5 Verify that all mounting locations are used
- 6 Attach bullbar to bracket using Herd supplied hinge bolts

* For DFLT & Defender models only: To install the hinge bolts, the bumper must be in the open (down) position to allow the bottom lip to go under and around the steel hinge.

- 7 Check to ensure bar is level relative to a significant feature of the truck, and readjust if necessary

- 8 Wire driving lights to existing wiring (if applicable)

- 9 Insert and tighten eyebolts (75-100 ft-lbs)

- 10 Re-check the mounting bracket and bolts after the first 5,000km and every 3-6 months.

Eyebolts are secured in the channel with a 7/8" rubber washer. If you need to re-install the washer, insert the eyebolt into the hole, and thread a washer onto the back side of the eyebolt, approximately halfway onto the threaded part of the eyebolt.

