



# INSTALLATION INSTRUCTIONS

## INTERNATIONAL

**Item #**                      **Vehicle Description**  
*IN13*                              *International ProStar*

### IMPORTANT

- A** Herd Bullbars are vehicle "Make & Model" specific. Use of a bullbar on a vehicle other than the model it was designed for will constitute improper use of the product and may void warranty.
- B** Unless otherwise specified, Grade 8 hardware is to be used. For the purposes of these instructions, OE hardware means the truck's original factory hardware.
- C** The drop-forged eyebolts are an integral part of the strength of Herd bullbars. When tightened firmly, they will minimize vibration and provide superior impact resistance.
- D** To help maintain the factory finish, avoid acid wash.

### Step

- 1 *Remove factory bumper*
- 2 *Install Herd sub mounts to truck using the three(3) bolt holes as circled (see picture)*
- 3 *Install Herd steel bracket to the sub mounts using Herd supplied hardware*
- 4 *Verify that all mounting locations are used*

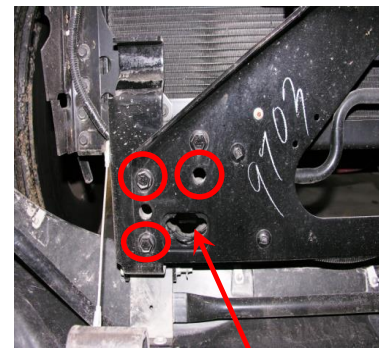

**TOW HOOK  
RECEIVER**

- 5 *Pass the ASSY-WLD TOW through the factory cross member panels, twist the ASSY-WLD TOW 90 degree to lock it with TOWHOOK RECEIVER. Tighten the ASSY-WLD TOW with a 3/4" flat washer and 3/4" lock nut, the factory tow receiver tension spring may need to be removed if it interferes with the ASSY-WLD TOW. One 5/8" x 2 1/2" Hex bolt and two 1/2" x 2 1/2" bolts on each side for mounting the Herd sub mount onto the factory cross member panel.*

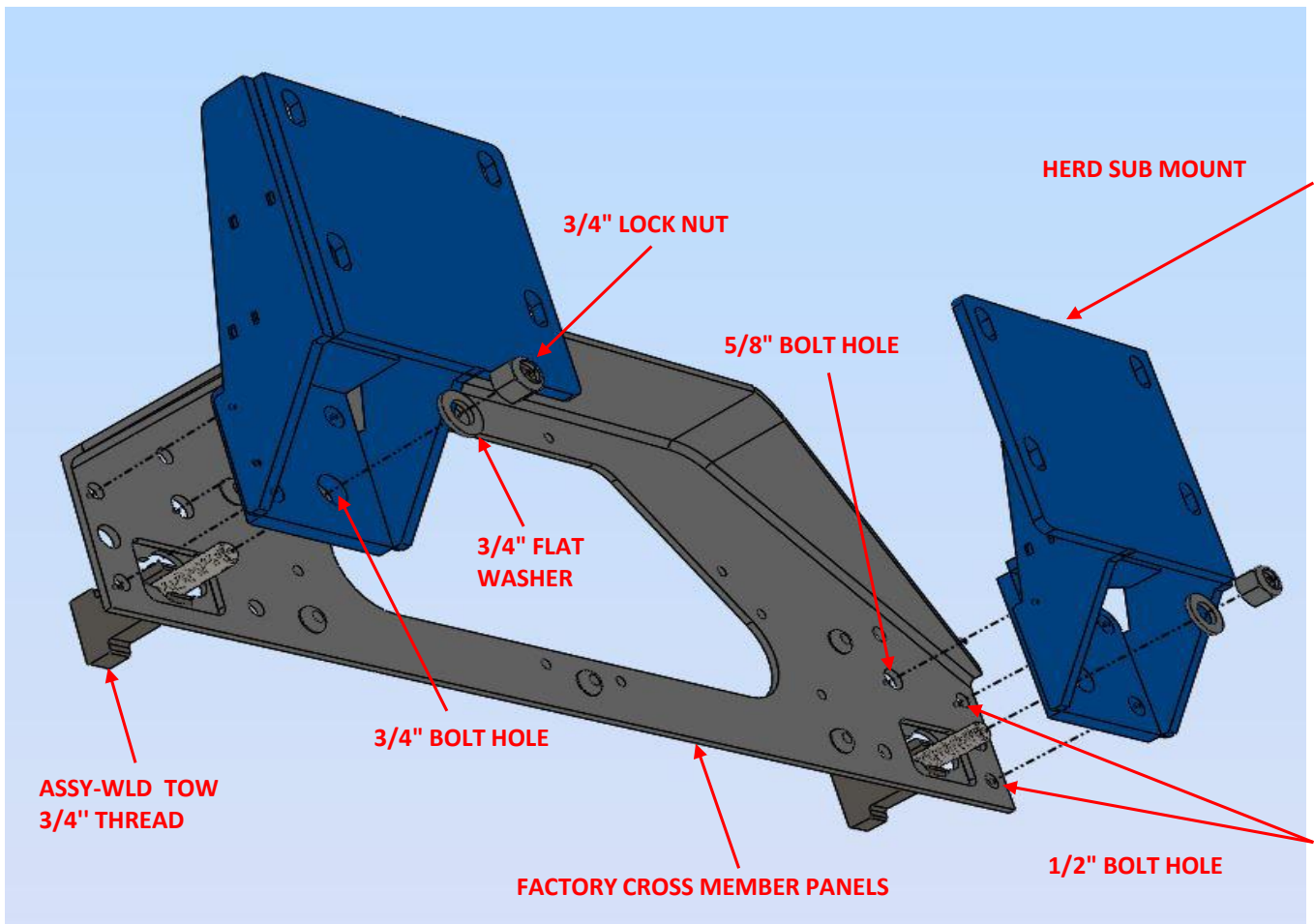

**6 Attach bullbar to bracket using Herd supplied hinge bolts**

**\* For DFLT & Defender models only:** To install the hinge bolts, the bumper must be in the open (down) position to allow the bottom lip to go under and around the steel hinge.

- 7 Check to ensure bar is level relative to a significant feature of the truck, and readjust if necessary**
- 8 Wire driving lights to existing wiring (if applicable)**
- 9 Insert and tighten eyebolts (75-100 ft-lbs)**
- 9 Re-check the mounting bracket and bolts after the first 5,000km and every 3-6 months.**

**Eyebolts are secured in the channel with a 7/8" rubber washer. If you need to re-install the washer, insert the eyebolt into the hole, and thread a washer onto the back side of the eyebolt, approximately halfway onto the threaded part of the eyebolt.**