



# INSTALLATION INSTRUCTIONS

## KENWORTH

Item #	Vehicle Description
KW12	KW T660 SBA (2007-2016)

---

### **IMPORTANT**

- A** Herd Bullbars are vehicle "Make & Model" specific. Use of a bullbar on a vehicle other than the model it was designed for will constitute improper use of the product and may void warranty.
- B** Unless otherwise specified, Grade 8 hardware is to be used. For the purposes of these instructions, OE hardware means the truck's original factory hardware.
- C** The drop-forged eyebolts are an integral part of the strength of Herd bullbars. When tightened firmly, they will minimize vibration and provide superior impact resistance.
- D** To help maintain the factory finish, avoid acid wash.

---

### Step

- 1 *Remove factory bumper*

- 2 *Install Herd Receiver Bracket into truck tow hook receivers. Locate Herd Mounting Bracket on the frame crossmember and space mounting bracket from towbox using 7/8" spacer supplied. Attach mounting bracket to the towbox with supplied 6 1/2" long 7/8" bolt, washer & locknut. Attach Herd mounting bracket to the crossmember using factory OEM hardware. Attach Herd mounting bracket to the bullbar bracket using supplied 1/2" Hardware (see Figure 1 below). Attach Bullbar bracket to Receiver bracket using supplied 3/4" hardware. NOTE: Trucks equipped with the ISX engine will use 2 of the supplied square spacers between mounting bracket, and crossmember to align the 7/8" bolt to the tow box pin hole.*

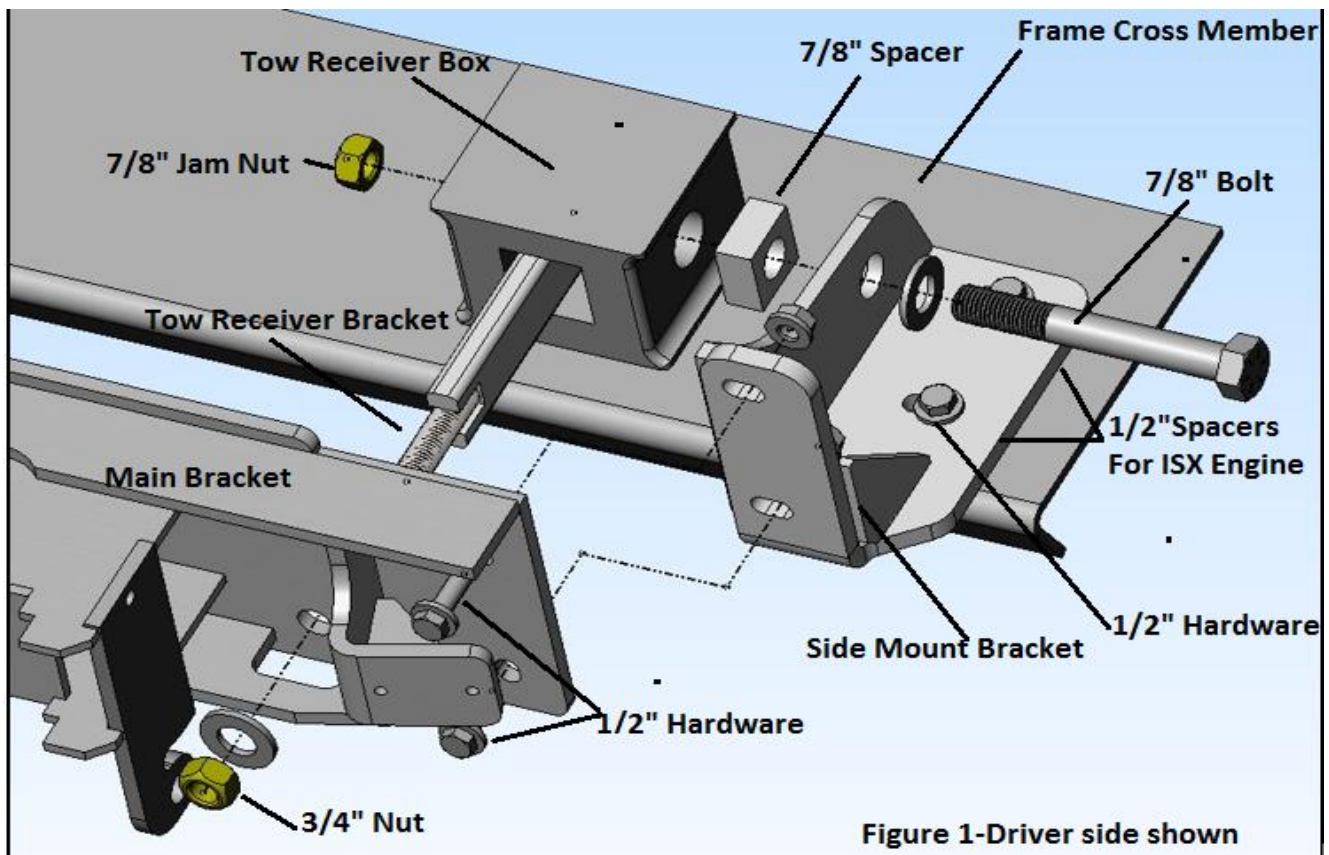

**Figure 1-Driver side shown**

- 3** *Verify that all mounting locations are used*
- 4** *Attach bullbar to bracket using Herd supplied hinge bolts*  
*\* For DFLT & Defender models only: To install the hinge bolts, the bumper must be in the open (down) position to allow the bottom lip to go under and around the steel hinge.*
- 5** *Check to ensure bar is level relative to a significant feature of the truck, and readjust if necessary*
- 6** *Wire driving lights to existing wiring (if applicable)*
- 7** *Insert and tighten eyebolts (75-100 ft-lbs)*
- 8** *Re-check the mounting bracket and bolts after the first 5,000km and every 3-6 months.*

*Eyebolts are secured in the channel with a 7/8" rubber washer. If you need to re-install the washer, insert the eyebolt into the hole, and thread a washer onto the back side of the eyebolt, approximately halfway onto the threaded part of the eyebolt.*