



INSTALLATION INSTRUCTIONS

MACK

Item #	Vehicle Description
MK11	Mack CHN/CHU (SFA) 2006+

IMPORTANT

- A** Herd Bullbars are vehicle "Make & Model" specific. Use of a bullbar on a vehicle other than the model it was designed for will constitute improper use of the product and may void warranty.
- B** Unless otherwise specified, Grade 8 hardware is to be used. For the purposes of these instructions, OE hardware means the truck's original factory hardware.
- C** The drop-forged eyebolts are an integral part of the strength of Herd bullbars. When tightened firmly, they will minimize vibration and provide superior impact resistance.
- D** To help maintain the factory finish, avoid acid wash.

NOTE: Some fasteners that need to be removed are HUCK fasteners. These fasteners are crimped on and cannot be twisted off. If not equipped to remove these fasteners, have a reputable shop perform this operation.

Step

- 1 Remove factory bumper. The two lower HUCK fasteners on the outer face of the frame rails will need to be removed on each side, see attached picture. The two factory outer brackets, attached to the brackets supported with the HUCK fasteners, are to be removed along with the factory tow loops and not reused for HERD bumper mounting.

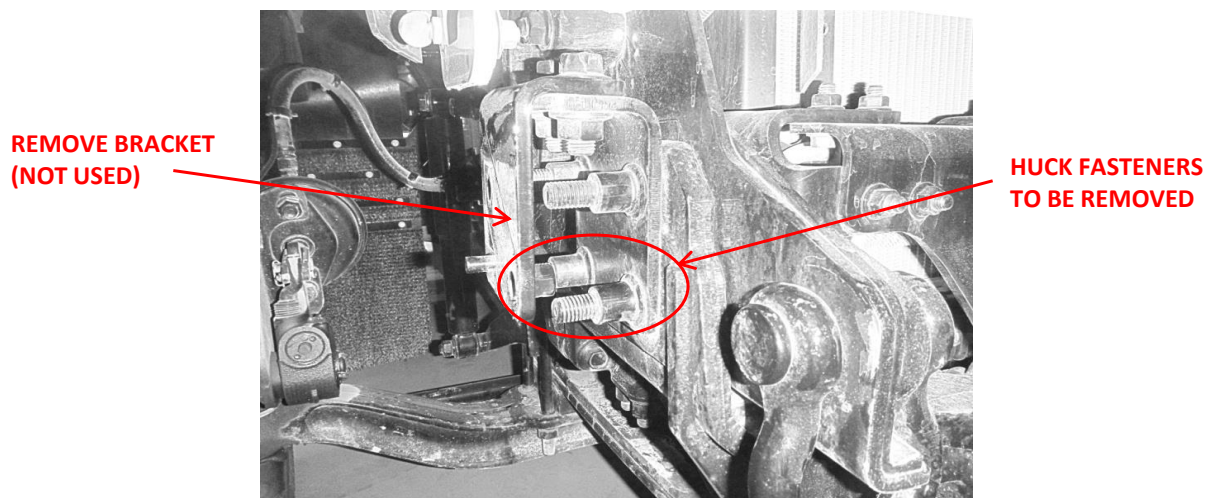

2 *Install Herd steel bracket to truck using hardware supplied with bar as shown.*

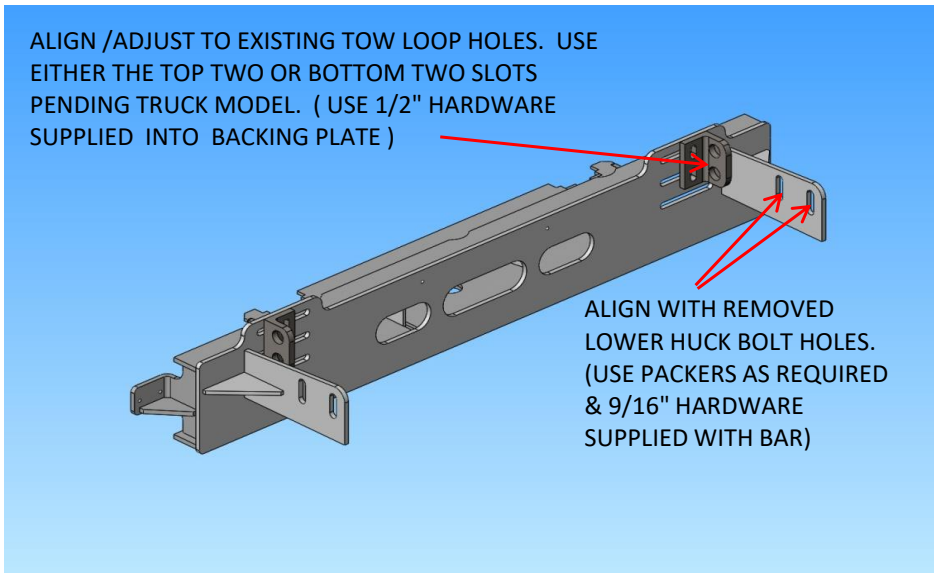

3 *Verify that all mounting locations are used*

4 *Check to ensure bar is level relative to a significant feature of the truck, and readjust if necessary*

5 *Attach bullbar to bracket using Herd supplied hinge bolts*

* For DFLT & Defender models only: To install the hinge bolts, the bumper must be in the open (down) position to allow the bottom lip to go under and around the steel hinge.

6 *Install OEM driving light as shown below (if applicable)*

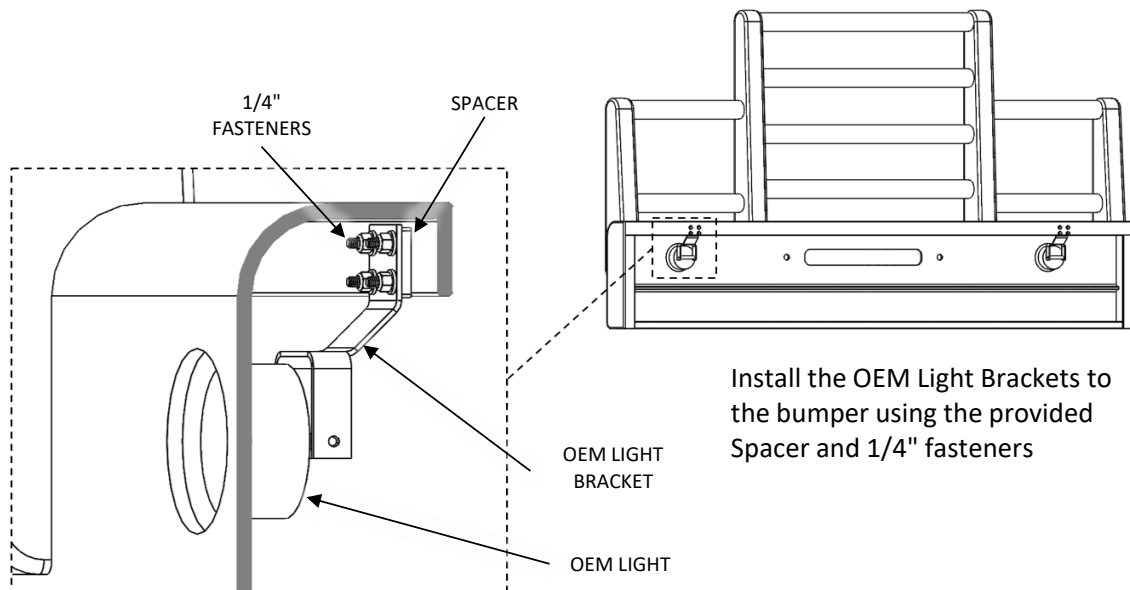

7 *Install/wire driving lights (Herd 6"oval, round, or surface mount) to existing wiring (if applicable)*

8 *Insert towpin and tighten eyebolts (75-100 ft-lbs)*

9 *Re-check the mounting bracket and bolts after the first 5,000km and every 3-6 months.*