



# INSTALLATION INSTRUCTIONS

## WESTERN STAR

Item #	Vehicle Description
WS17	Western Star 4700 SFA

### IMPORTANT

- A** Herd Bullbars are vehicle "Make & Model" specific. Use of a bullbar on a vehicle other than the model it was designed for will constitute improper use of the product and may void warranty.
- B** Unless otherwise specified, Grade 8 hardware is to be used. For the purposes of these instructions, OE hardware means the truck's original factory hardware.
- C** The drop-forged eyebolts are an integral part of the strength of Herd bullbars. When tightened firmly, they will minimize vibration and provide superior impact resistance.
- D** To help maintain the factory finish, avoid acid wash.

### Step

- 1 *Remove factory bumper*

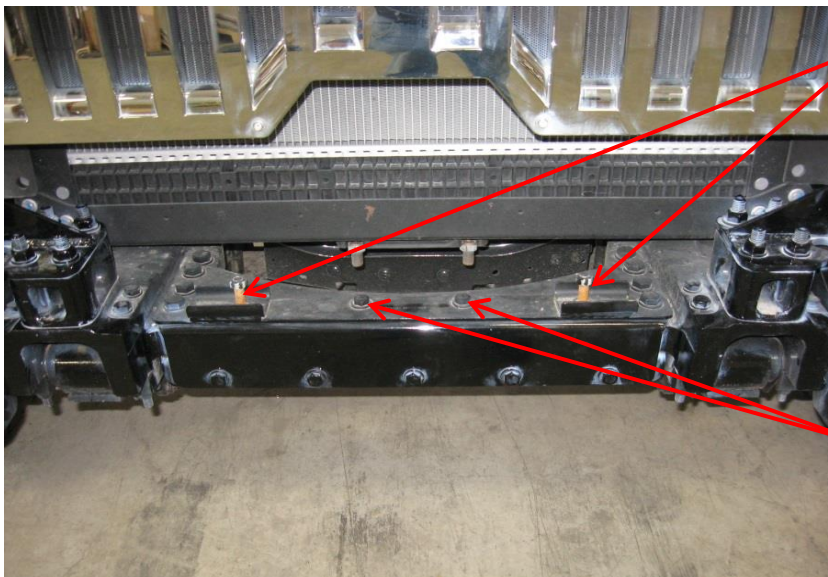

REMOVE TOW  
LOOPS

REMOVE BOLTS FOR  
SUB-MOUNT  
PLACEMENT

**2** *Install Herd steel bracket to truck using supplied hardware*

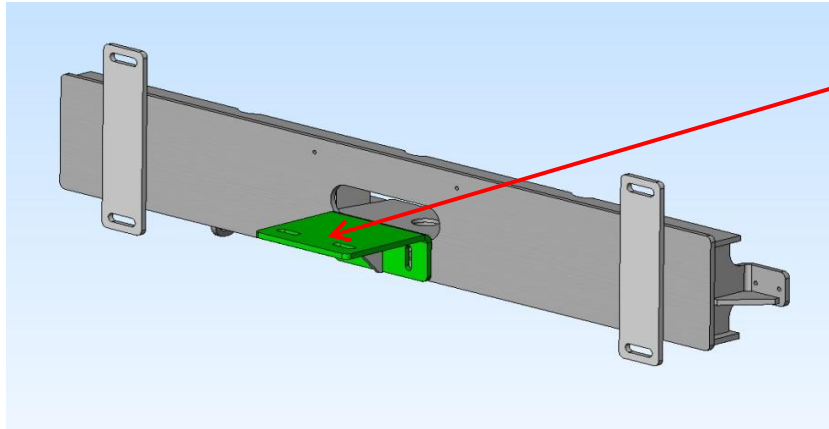

SUB-MOUNT  
SITS ON TOP  
OF CROSSMEMBER

**3** *Verify that all mounting locations are used*

**4** *Attach bullbar to bracket using Herd supplied hinge bolts*

*\* For DFLT & Defender models only: To install the hinge bolts, the bumper must be in the open (down) position to allow the bottom lip to go under and around the steel hinge.*

**5** *Check to ensure bar is level relative to a significant feature of the truck, and readjust if necessary*

**6** *Wire driving lights to existing wiring (if applicable)*

**7** *Insert towpin and tighten eyebolts (75-100 ft-lbs)*

**8** *Re-check the mounting bracket and bolts after the first 5,000km and every 3-6 months.*

*Eyebolts are secured in the channel with a 7/8" rubber washer. If you need to re-install the insert the eyebolt into the hole, and thread a washer onto the back side of the eyebolt, halfway onto the threaded part of the eyebolt.*