

- This document shows how to install your new Truck Guard onto your truck.
- Ensure that you have completely read and understand document **S017 - Safety** before beginning this installation procedure.

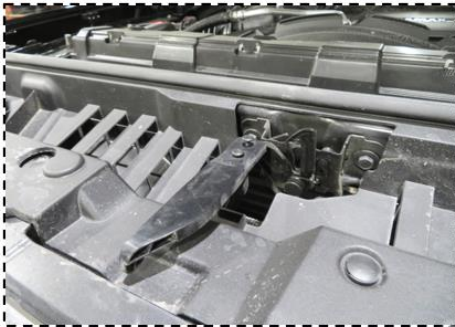

Figure 1a: Remove latch handle



Figure 1b: Remove radiator cover



Figure 1c: Remove fender liner screws (passenger side shown)



Figure 1e: Remove valance (passenger side shown)



Driver side valance



Figure 1d: Uncovered fender flare (driver side shown)

Figure 1: Removing the OEM front bumper - Part 1 (Your Truck may not be exactly as shown)

I. Removing the OEM front bumper (please keep all OEM fasteners for reassembling later)

1. Open the hood and remove the latch handle as shown in Figure 1a.
2. Remove the radiator cover by removing the plastic clips, see Figure 1b.
3. Remove the fender liner screws as shown in Figure 1c and pull the fender liner away from the fender.
4. Pull the fender flare off halfway to reveal the valance screws (1 per side), see Figure 1d. Remove the screws.
5. The block heater connector (if applicable) is hidden behind the driver side valance. The main harness connector is hidden behind the passenger side valance. Remove the valances, both driver and passenger side, as shown in Figure 1e. The connectors can now be accessed and unplugged.



Figure 2b: Unplug the camera connector

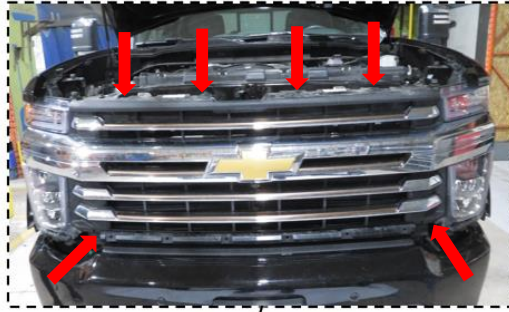

Figure 2a: Remove front grille



Figure 2d: Remove bumper fasteners (driver side shown)

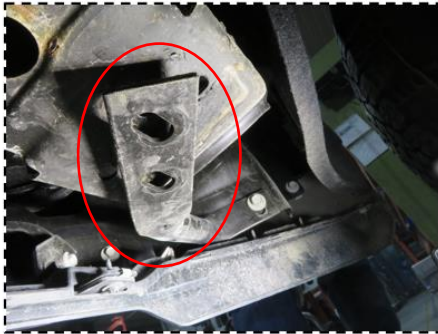

Figure 2c: Remove bottom fasteners (passenger side shown)



Figure 2e: Remove bumper

Figure 2: Removing the OEM front bumper - Part 2 (Your Truck may not be exactly as shown)

6. Remove the front grille by first removing top 4 screws and the bottom 2 screws, follow red arrows shown in Figure 2a, then pull the front grille away from truck to release clips. If the truck has front camera, remove the camera connector before completely removing the front grille, see Figure 2b.
7. Remove the bottom mounting fasteners (2 per side). The fasteners can be accessed from under the truck, see Figure 2c.
8. Remove the 4 bumper fasteners hidden inside the bumper by facing the truck and looking down the bumper. Figure 2d shows the 2 fasteners on driver side.
9. Remove the OEM front bumper. Unplug the louver system (the connector can be accessed from the bottom, see red arrow in Figure 2e) then remove the 2 truck bumper mounts (4 front fasteners per side, red circles in Figure 2e) together with the louver system. Remove the louver system from the bumper mounts and the OEM tow loops from the truck. They will be reused with HERD Truck Guard.
10. Perform steps 6, 5, 4, 3, 2, and 1 in reverse to reattach the grille, the valence, the fender flare, the fender liner, the radiator cover, and the latch handle back to the truck. Keep the main harness and block heater cable (if applicable) unplugged.

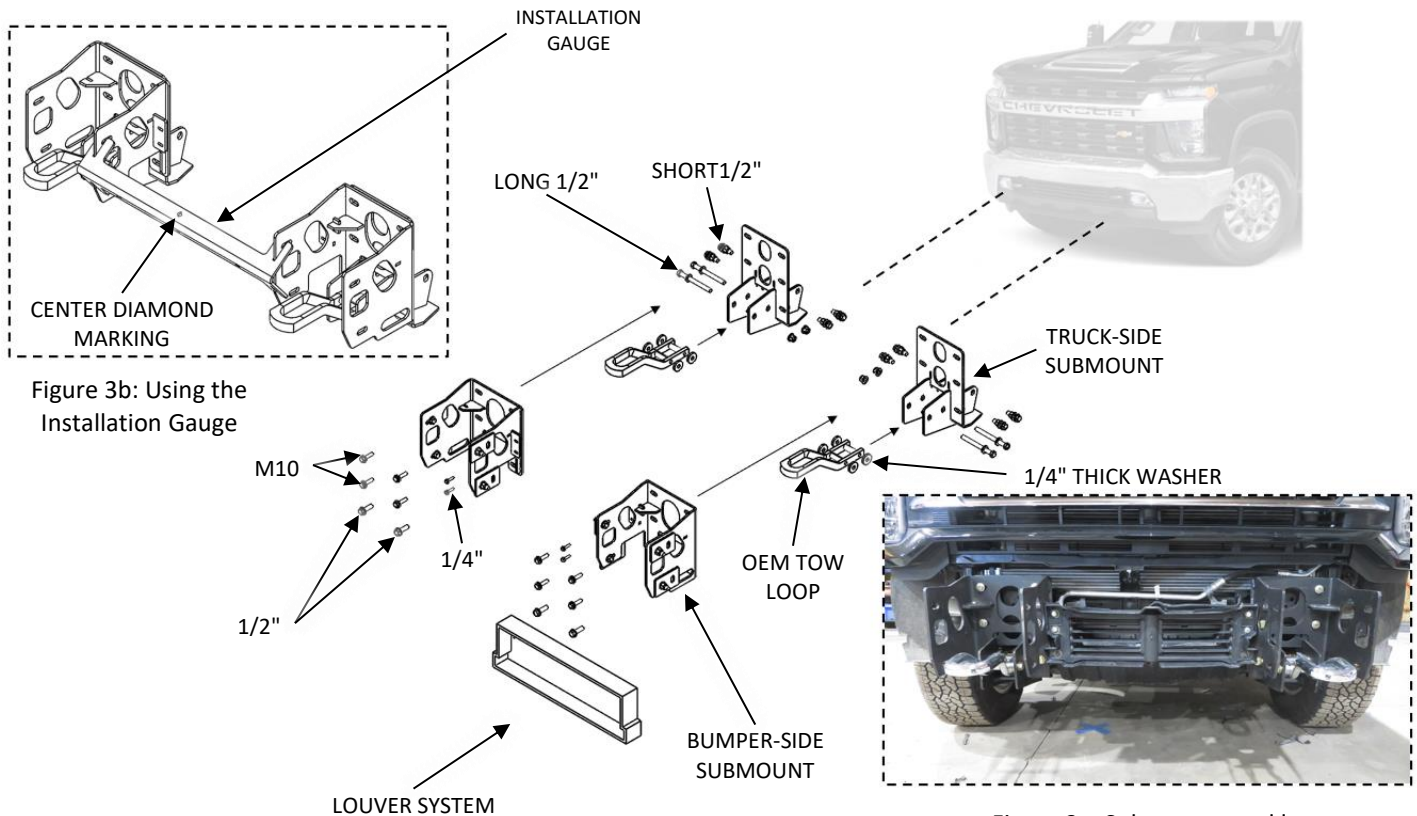

Figure 3a: Submounts and louver system installation

Figure 3: Installing the Submounts

II. Installing the Submounts

1. Install the Truck-Side Submounts, shown in Figure 3, using the provided fasteners (short 1/2") from the side of truck frame. **Torque the short 1/2" fasteners to 96 ft-lb.**
2. Install the Bumper-Side Submounts to the front of the Truck-Side Submounts using the provided fasteners (M10 and short 1/2"), fasten loosely. Install the louver system between the Truck-Side Submounts using the provided fasteners (1/4"). Because the louver system is plastic, do not over tighten the fasteners. The Submounts and louver system set up should look like Figure 3a.
3. Install the OEM tow loops to the Truck Side Submounts using the provided fasteners (use the long 1/2" together with the 1/4" Thick Washer as spacer), see Figure 3. **Torque the long 1/2" fasteners to 96 ft-lb.**
4. Use the Installation Gauge to position the Submounts; the center diamond marking should line up with the center of the truck, see Figure 3b.
5. With the Installation Gauge still in position, tighten all mounting fasteners. **Torque the M10 fasteners to 48 ft-lb; torque the short 1/2" fasteners to 96 ft-lb.**
6. Remove the Installation Gauge.

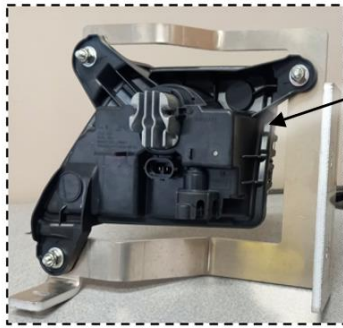

Figure 4a: OEM horizontal fog light installation (driver side shown)

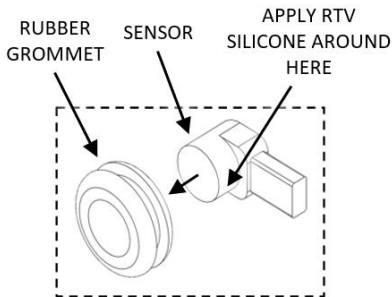

Figure 4d: Sensor installation

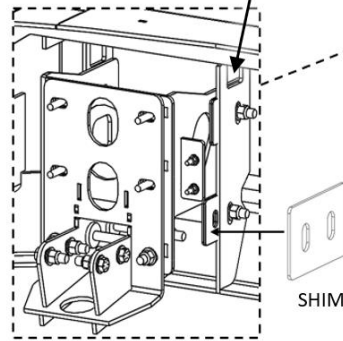

Figure 4b: Truck Guard installation (driver side shown)

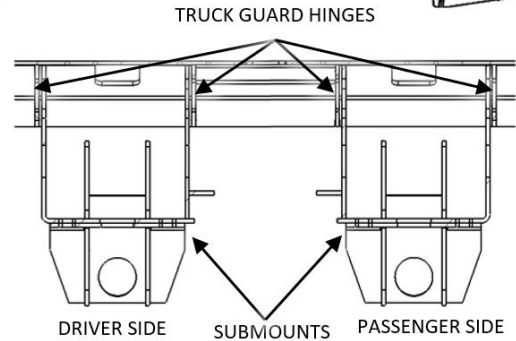

Figure 4c: Submounts position (top view)

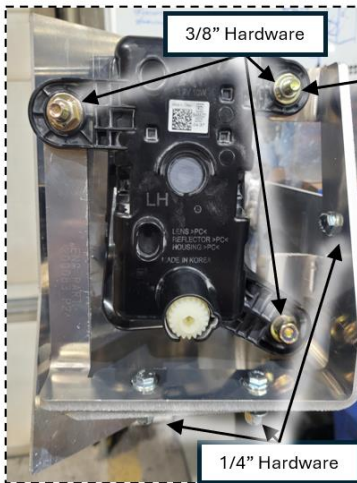

Figure 4e: OEM vertical fog light installation (driver side shown)

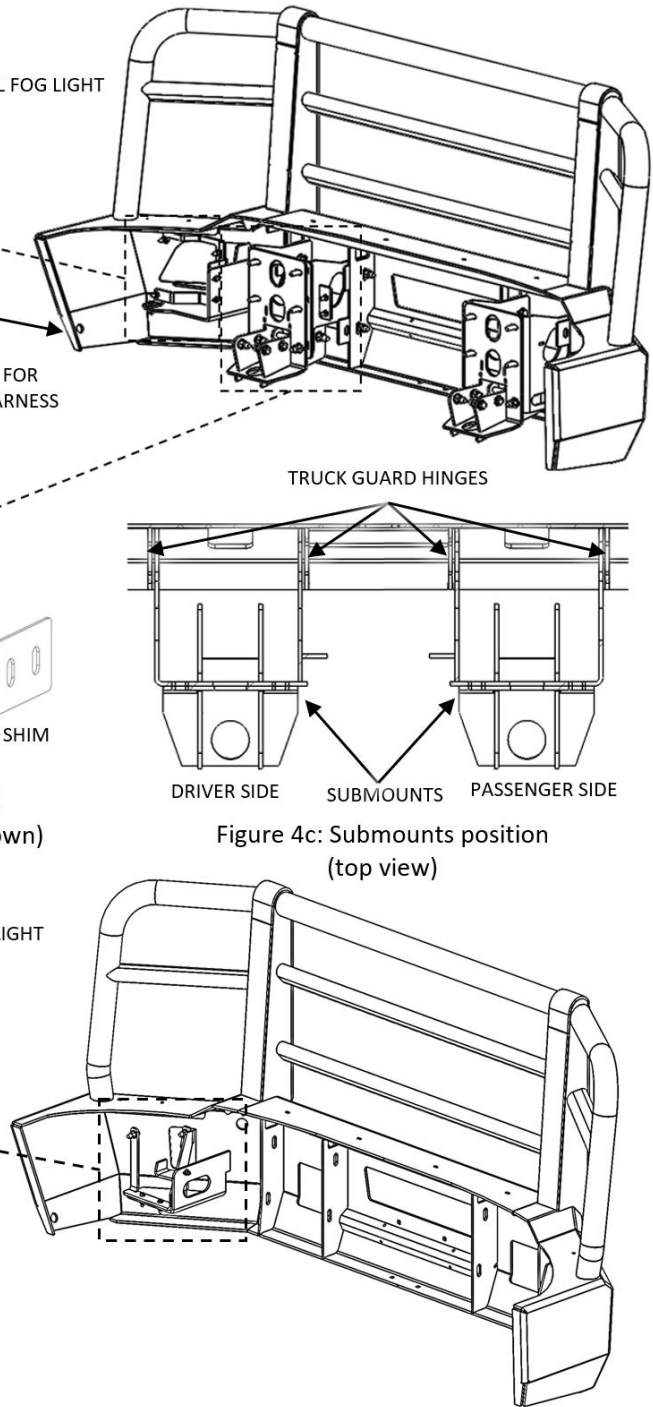

Figure 4: Installing the Truck Guard (view from behind)

III. Installing the HERD Truck Guard

1. Remove the OEM fog lights from the OEM front bumper (if applicable).
2. Install the OEM fog lights to HERD Truck Guard (if applicable); select the option that matches your truck:
 - a. For truck with **Horizontal** OEM fog lights, install the OEM fog light on the Light Bracket, then install Light Bracket and OEM fog light assembly to the HERD Truck Guard as shown in Figure 4a. Repeat this step on the other side of truck.
 - b. For truck with **Vertical** OEM fog lights, install the OEM fog light on the Light Bracket, then install Light Bracket and OEM fog light assembly to the HERD Truck Guard as shown in Figure 4e. Repeat this step on the other side of truck.
3. Remove the block heater cable from the OEM front bumper (if applicable). Install the cable to the provided hole on the HERD Truck Guard driver side bottom corner.
4. Attach the HERD Truck Guard to the Submounts, **follow the position shown in Figure 4b and Figure 4c**. Use the provided Shims if required. Adjust the HERD Truck Guard if necessary. Tighten all mounting fasteners (1/2") after adjustment, and **torque to 96 lb-ft**.
5. If the truck has parking sensors, remove them from the OEM front bumper (sensor's bezel is not required) together with wiring harness. Take note of the location of each sensor and harness. Apply RTV silicone all around the cylindrical section of the sensors, then insert the sensors through the rubber grommets on the HERD Truck Guard, see Figure 4d. Ensure locations of the sensors match where they were located on the OEM front bumper.
6. Let the adhesive cure in room temperature. Plug main harness into each sensor, and each fog light. Plug main harness and block heater cable back to the truck. Check if each sensor functions normally.

Important: Check mounting point's hardware after the first 5000 km and every 3-6 months. Re-torque if necessary.